



*City Council Memorandum*

**To:** Mayor Fasbender & City Council  
**From:** Eric Maass, Economic Development Coordinator  
**Date:** April 5, 2021  
**Item:** Public Hearing for Parklet, Sidewalk Café, and Liquor License Amendments related to American Legion, El Mexican, Onion Grille, Spiral Brewery and The Busted Nut.

**Council Action Requested:**

Hold a public hearing to consider approval of the proposed Parklets and Sidewalk Café license and Liquor License amendment for American Legion, El Mexican, Onion Grille, Spiral Brewery and The Busted Nut. The Ordinance requires applicants to enter a license agreement confirming their insurance and indemnification requirements and any action approving the Parklet and Sidewalk Café Licensee's amendment will include approval of the proposed licensee agreements which are attached with the application materials.

Staff has reviewed the requirements for compact and contiguous with the State of Minnesota and received in writing that as proposed both the sidewalk café and parklet would conform with State laws related to the issuance of liquor licenses.

City departments including building, planning, police, fire, and engineering have reviewed the proposed parklets, sidewalk cafes, and amended liquor licenses and recommends approval as requested with the following conditions:

1. American Legion cannot hold events within its event space while also utilizing a sidewalk café due to occupancy load and limitations with the bathrooms the facility currently has available. Their sidewalk café shall not consist of snow barrier fencing.
2. The Busted Nut parklet license be approved on condition that the City adopts a proposed ordinance that would amend the setback from the centerline of the road for parklets located on angular parking stalls from twenty feet to eighteen feet.
3. All sidewalk cafés and parklets shall adhere with American Disabilities Act (ADA).
4. Parklets shall be made available by licensee for inspection by building department and public works staff during installation.

**Background Information –**

**A. American Legion Sidewalk Café and Liquor License Amendment**

The Applicant has proposed a sidewalk café adjacent to the existing outdoor patio as well as a second sidewalk café within the grassy area to the north of the restaurants entrance.

The Applicant has proposed a sidewalk café adjacent to the existing outdoor patio as well as a second sidewalk café within the grassy area to the north of the restaurants entrance. Staff is comfortable with the sidewalk café requested based on the conditions outlined in the requested action section above.

**B. El Mexican Parklet and Liquor License Amendment**

The Applicant has proposed a 20'x 15' parklet. The parklet will be a wood frame construction and has been reviewed by City Staff. Staff supports the parklet as requested.

**C. Onion Grille Sidewalk Café and Liquor License Amendment**

The Applicant has proposed a 50' long by 7' wide sidewalk café. The Onion Grill building itself measures 50' long so it would stretch the length of the restaurant. Public safety noted that the north edge of the sidewalk café will need to be inspected to ensure that delivery trucks can safely navigate into the back alley. Once installed, Staff will inspect the sidewalk café to check for that safety concern as well as check to ensure that there is at least 4 feet of accessible sidewalk to ensure compliance with ADA.

**D. Spiral Brewery Parklet and Liquor License Amendment**

The Applicant has proposed a 20'x 18' parklet. Staff has worked with the Applicant on parklet concerns related to stormwater drainage and based on supplemental information submitted, Staff is comfortable with the parklet as proposed.

**E. The Busted Nut Sidewalk Café, Parklet, and Liquor License Amendment**

The Applicant has proposed a 20'x 18' parklet as well as a 5' x 20' sidewalk café. The sidewalk café is proposed to be placed on the north side of the sidewalk directly adjacent to the proposed parklet. In previous years the sidewalk café for The Busted Nut was located directly adjacent to the building. The newly proposed location will have less impacts on the pedestrian experience and will provide approximately 8' of open sidewalk to ensure conformance with ADA which requires a minimum width of 4' of sidewalk clearance.

**Financial Impact:**

All license fees have been paid.

**Advisory Commission Discussion:**

N/A

**Attachments:**

Application materials

License agreements

17 Mar 2021  
- received: COI, menu,  
photo of furniture

17 Mar 2021  
IX-01 & X-C-01  
- received application  
- emailed about missing info

23 Mar 2021  
**Sidewalk Cafe Application** - received photo of  
kammer/fence  
City Code Chapter 90.16



**Fees:**

License \$50.00  
Liquor License  
(If serving liquor in  
the sidewalk café) \$50.00

**Contact Information**

BUSINESS INFORMATION	Name: American Legion Post 47
	Address: 50 Subley St Hastings
	Phone: 651-437-2046

APPLICANT INFORMATION	Name: Roxanne S Gerlach
	Phone: 651-503-5071
	Address:
	Email: hastingslegionpost47@gmail.com

**Sidewalk Café Description**

Street Name	Length x Width	Number of tables	Number of Seats

refer to  
attached  
drawing -  
EMJ

Days and Hours of sidewalk café operation: 10am-11pm

Describe any entertainment or music:

Will alcoholic beverages for consumption be offered in the sidewalk café? NO  YES   
(If yes, please complete the next section.)

**Sidewalk Café Area to Serve Alcohol (Liquor License Amendment)**

Will alcoholic beverages be served in the entirety of the sidewalk café? NO  YES   
If no, specify where alcohol will be served?

Days and Hours of alcohol service: Every day - 10am - 11pm

Has staff received required alcohol training: NO  YES

Procedure ensuring alcohol will be contained in café:

It will be enclosed, and our Adequate  
be watching carefully.

## Application Checklist

	Application Form
	Proposed sidewalk café diagram including furniture specifications; if applicable, specify area to serve alcohol
	Food and beverage menu
	Proposed sound or entertainment
	Ordinance Review Form
	Proof of insurance. <i>All proofs of insurance must include in the description:</i> <ul style="list-style-type: none"> <li>• City of Hastings is included as an additional insured. A 10-day cancellation notice is included as part of the policy.</li> </ul> <i>If serving alcohol, the following must be included in the description:</i> <ul style="list-style-type: none"> <li>• Coverage extends to adjacent sidewalk and off premises events.</li> </ul>
	\$50.00 Application Fee
	\$50.00 Liquor License Amendment Fee

## Data Practices Notice

Every city in Minnesota must comply with the Minnesota Government Data Practices Act (MGDPA), which, in conjunction with other state and federal laws, classifies all government data. Government data are classified in different categories depending on whether they are accessible by the public.

Government data means all data collected, created, received, maintained or disseminated by the City regardless of its physical form, storage media or conditions of use. There is a presumption that government data are public and are accessible by the public for inspection and copying unless there is a federal law, state statute or temporary classification of data that provides differently.

The data supplied in this application will be used to assess the qualifications for a license. This data is not legally required but the City will not be able to grant the license without it. If a license is granted, the data will constitute a public record. The data is needed to distinguish this application from others, to identify this application in city license files, to verify the identity of the applicant, to contact the applicant if additional information is required and to determine if the applicant meets all ordinance requirements.

*I hereby certify that all statements made in this application are true and complete and understand that any misstatements or omissions of material facts may result in disqualification or denial of the license. I agree to abide by the provisions of this application and all applicable City policies and ordinances.*

Signature:

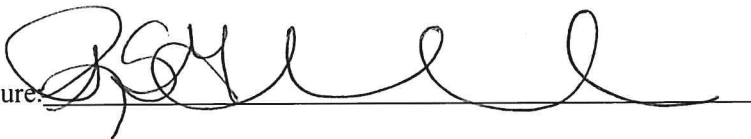

Date:

3-15-2021

Submit Application and Fees to:  
 Erica Henderson  
 Deputy City Clerk  
 101 4<sup>th</sup> Street East  
 Hastings, MN 55033  
[ehenderson@hastings.mn.gov](mailto:ehenderson@hastings.mn.gov)  
 651-480-2343

**City of Hastings  
Acknowledgement of  
Review of Ordinance**

I hereby acknowledge that I have read, understand and agree to abide by the regulations set forth in the City's Ordinance associated with the license for which I am applying. Furthermore, I also understand that I must comply with the provisions of all applicable state laws.

A handwritten signature in black ink, appearing to be "J. Miller", written over a horizontal line.

Applicant Signature

3-15-2021

Date

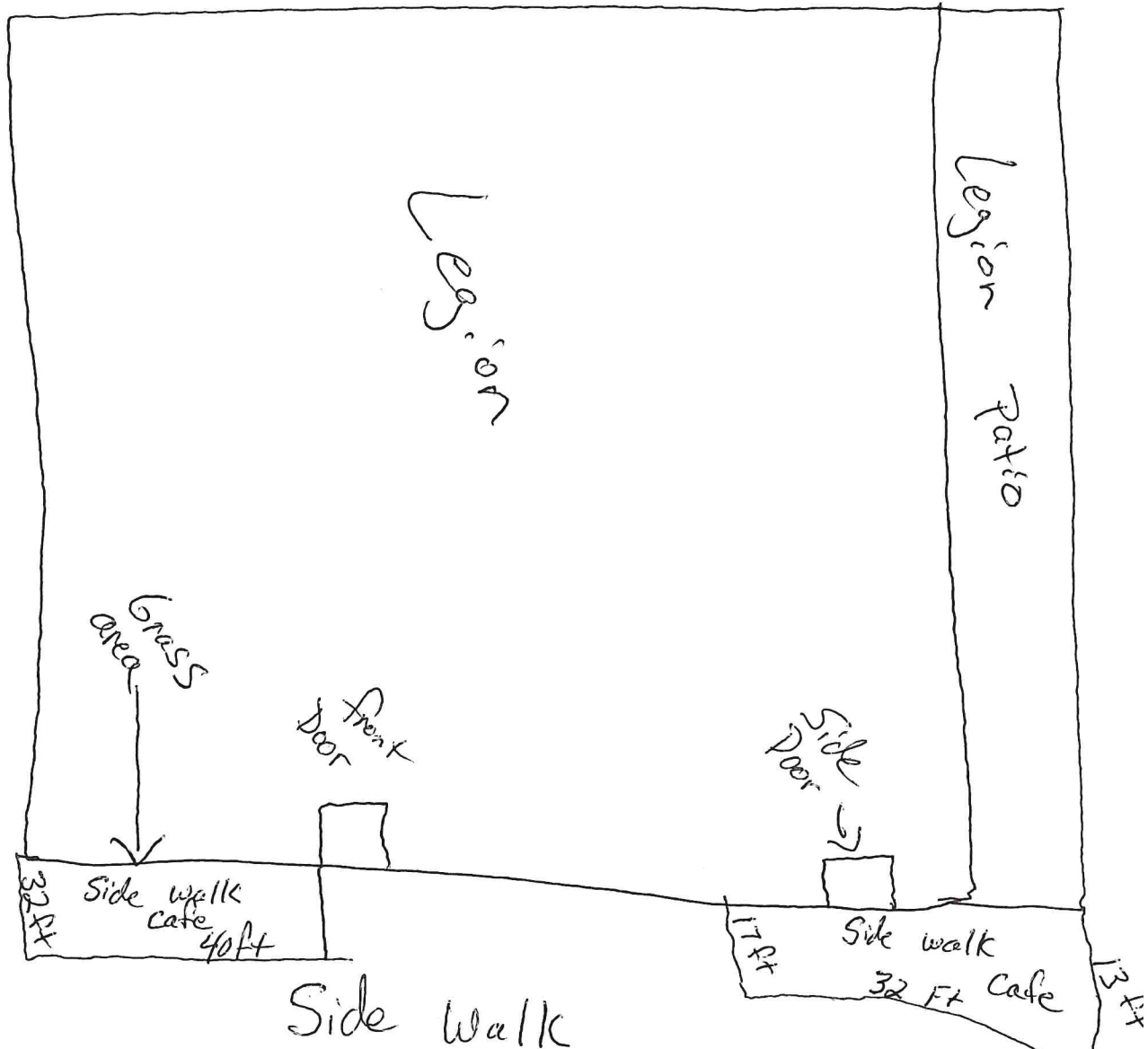

\*all distances b/w sidewalk cafe areas & curb are 4'- per conversation w/ applicant -EM 17 Mar 2021

Per email correspondence with application on 18 March 2021-  
So here is what we want from the corner of our building to the side walk we will rope off and then run the length of the side walk down to our metal railing to be blocked off. So that will leave us with the open grass is where we would be putting up our tables on that section. The other half that we want to block off is down where are patio is. We will not be blocking any part of the handicap parking spots or the ramps. There will be 4ft from the curb to the middle of the sidewalk for a walk way for people.



**TWO TOP AND FOUR TOP TABLES**



**SIX TOP TABLE**

## IX-01 & X-C-01



- Fencing/barrier
- will be connected with rope



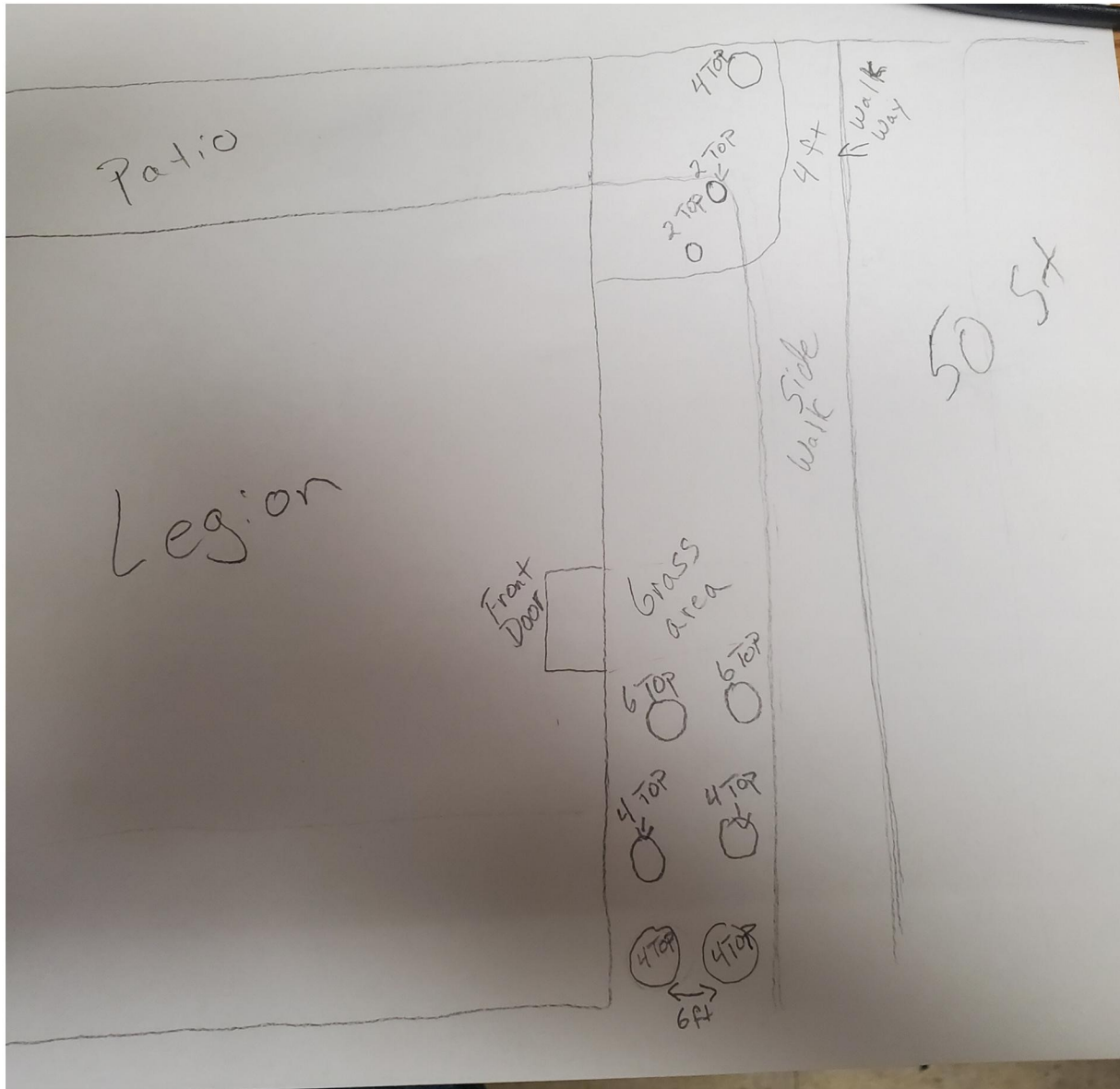

Sketch showing configuration of tables.  
COVID restrictions will be followed.

**New Parklet Application**

City Code Chapter 90.17



**Fees:**

\_\_\_\_\_ License \$100.00  
 \_\_\_\_\_ Liquor License \$50.00  
 (If serving liquor in the parklet)

**Contact Information**

BUSINESS INFORMATION	Name: 21 Mexican Restaurant Hastings
	Address: 111 2nd St E Hastings MN 55035
	Phone: 651 437 5002

CONTACT PERSON INFORMATION	Name: David Perez
	Phone: 763 843 9027
	Address: 1135 167th St Hammond WI 54015
	Email: pmexicanrestaurant@gmail.com

**Parklet Description**

Days of Parklet Operation: Mon - Sun	Hours of Parklet Operation: 11am - 9pm / Fri - Sun 10am - 9pm
Description of all points of access between the building and the parklet and exterior areas. 2 doors on the front of the building 2 points of exit/entry on parklet	
Describe the fencing/barrier to denote parklet area.	
Description of ingress and egress arrangements including those necessary to provide handicap accessibility and to ensure safety of moveable seating arrangements. Platform will be flushed with sidewalk w/ft opening to accommodate handicap.	
Description of all physical improvements to be constructed to accommodate the parklet.	
Describe any entertainment or music. Speaker on outside of building is all that's available no music on the structure	
Describe any additional lighting. Solar Powered lighting.	

There is only one point of entry to the parklet-eah 23 march 2021

\* will follow Covid restrictions - spoke w/ applicant EAH 23 Mar 2021

Any other information and details:

Will alcoholic beverages for consumption be offered in the parklet? NO  YES   
*(If yes, please complete the next section.)*

**Parklet to Serve Alcohol (Liquor License Amendment)**

Will alcoholic beverages be served in the entirety of the parklet? NO  YES   
*If no, specify where alcohol will be served?*

Days and hours of alcohol service: Mon - Thurs 11 - 8pm Sun 10 - 9,  
 Fri - Sat 10 - 11pm

Has staff received required alcohol training: NO  YES

Procedure ensuring alcohol will be contained in parklet: Signs will be posted where boundaries of alcohol is allowed, servers and staff are trained to communicate this to customers.

**Other Required Documents**

-Parklet diagram

-Refer to City Code Section 90.17(G)(2)(a) for required diagram specifications

-Photographs and manufacturer specifications for all proposed parklet furniture and fixtures.

-Certificate of Insurance

All proofs of insurance must include in the description:

-City of Hastings is included as an additional insured. A 10-day cancellation notice is included as part of the policy.

If serving alcohol, the following must be included in the description: Coverage extends to adjacent sidewalk and off premises events.

-Food and Beverage Menu

**Application Checklist**

	Application Form
	Proposed parklet diagram including furniture specifications.
	Food and beverage menu
	Proposed sound or entertainment
	Ordinance Review Form
	Certificate of insurance. <i>All proofs of insurance must include in the description:</i> <ul style="list-style-type: none"> <li>• City of Hastings is included as an additional insured. A 10-day cancellation notice is included as part of the policy.</li> </ul> <i>If serving alcohol, the following must be included in the description:</i> <ul style="list-style-type: none"> <li>• Coverage extends to adjacent sidewalk and off premises events.</li> </ul>
	\$100.00 Application Fee
	\$50.00 Liquor License Amendment Fee (if applicable)

**Data Practices Notice**

Every city in Minnesota must comply with the Minnesota Government Data Practices Act (MGDPA), which, in conjunction with other state and federal laws, classifies all government data. Government data are classified in different categories depending on whether they are accessible by the public.

Government data means all data collected, created, received, maintained or disseminated by the City regardless of its physical form, storage media or conditions of use. There is a presumption that government data are public and are accessible by the public for inspection and copying unless there is a federal law, state statute or temporary classification of data that provides differently.

The data supplied in this application will be used to assess the qualifications for a license. This data is not legally required but the City will not be able to grant the license without it. If a license is granted, the data will constitute a public record. The data is needed to distinguish this application from others, to identify this application in city license files, to verify the identity of the applicant, to contact the applicant if additional information is required and to determine if the applicant meets all ordinance requirements.

*I hereby certify that all statements made in this application are true and complete and understand that any misstatements or omissions of material facts may result in disqualification or denial of the license. I agree to abide by the provisions of this application and all applicable City policies and ordinances.*

Signature: \_\_\_\_\_



Date: \_\_\_\_\_

3/21/21

Submit Application and Fees to:

Erica Henderson

Deputy City Clerk

101 4<sup>th</sup> Street East

Hastings, MN 55033

[ehenderson@hastings.mn.gov](mailto:ehenderson@hastings.mn.gov)

651-480-2343

**City of Hastings  
Acknowledgement of  
Review of Ordinance**

I hereby acknowledge that I have read, understand and agree to abide by the regulations set forth in the City's Ordinance associated with the license for which I am applying. Furthermore, I also understand that I must comply with the provisions of all applicable state laws.



\_\_\_\_\_  
Applicant Signature

8-23-21

\_\_\_\_\_  
Date

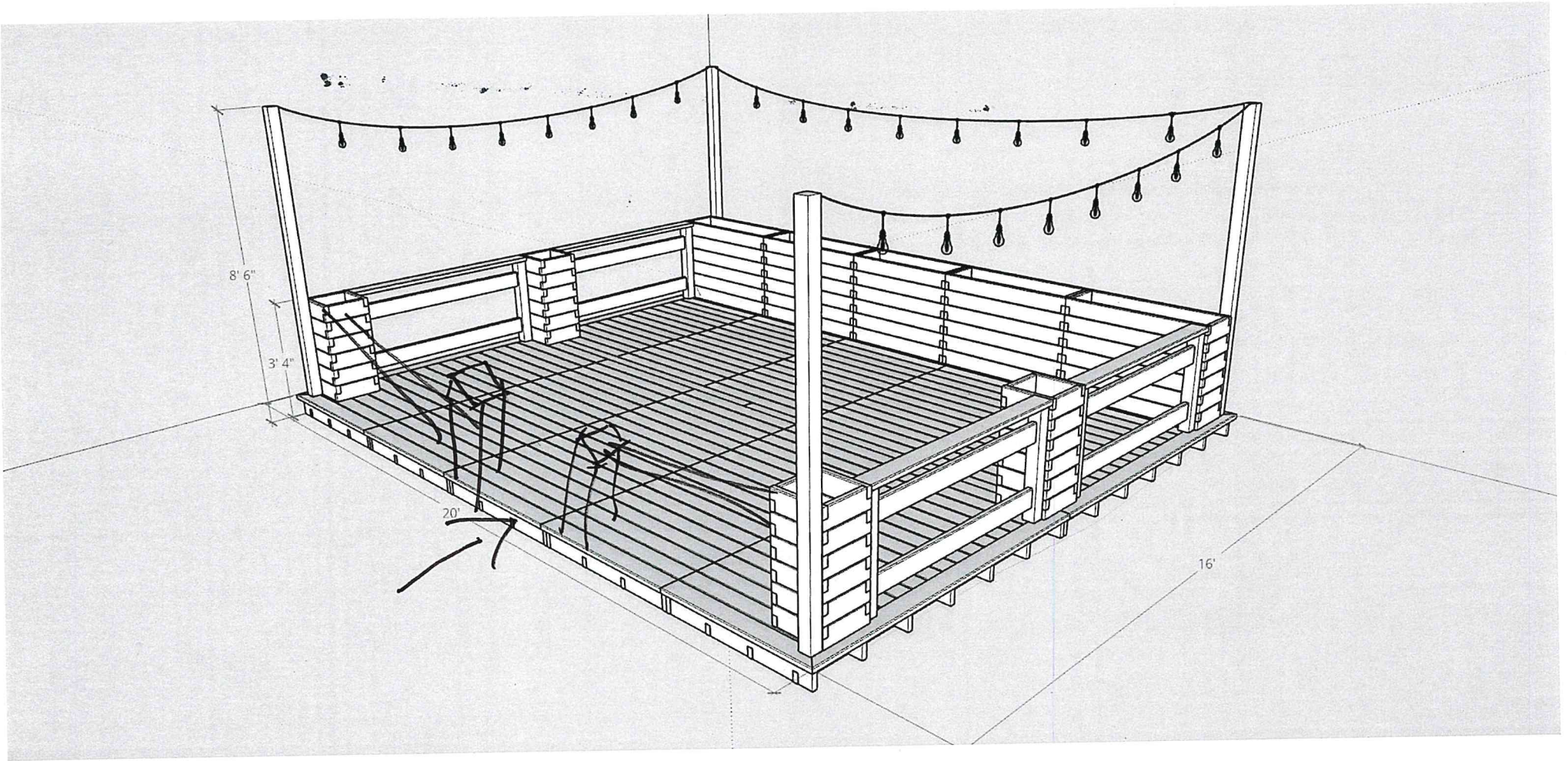

Showing Entrance/Exit

Open Rail  
Like Sides

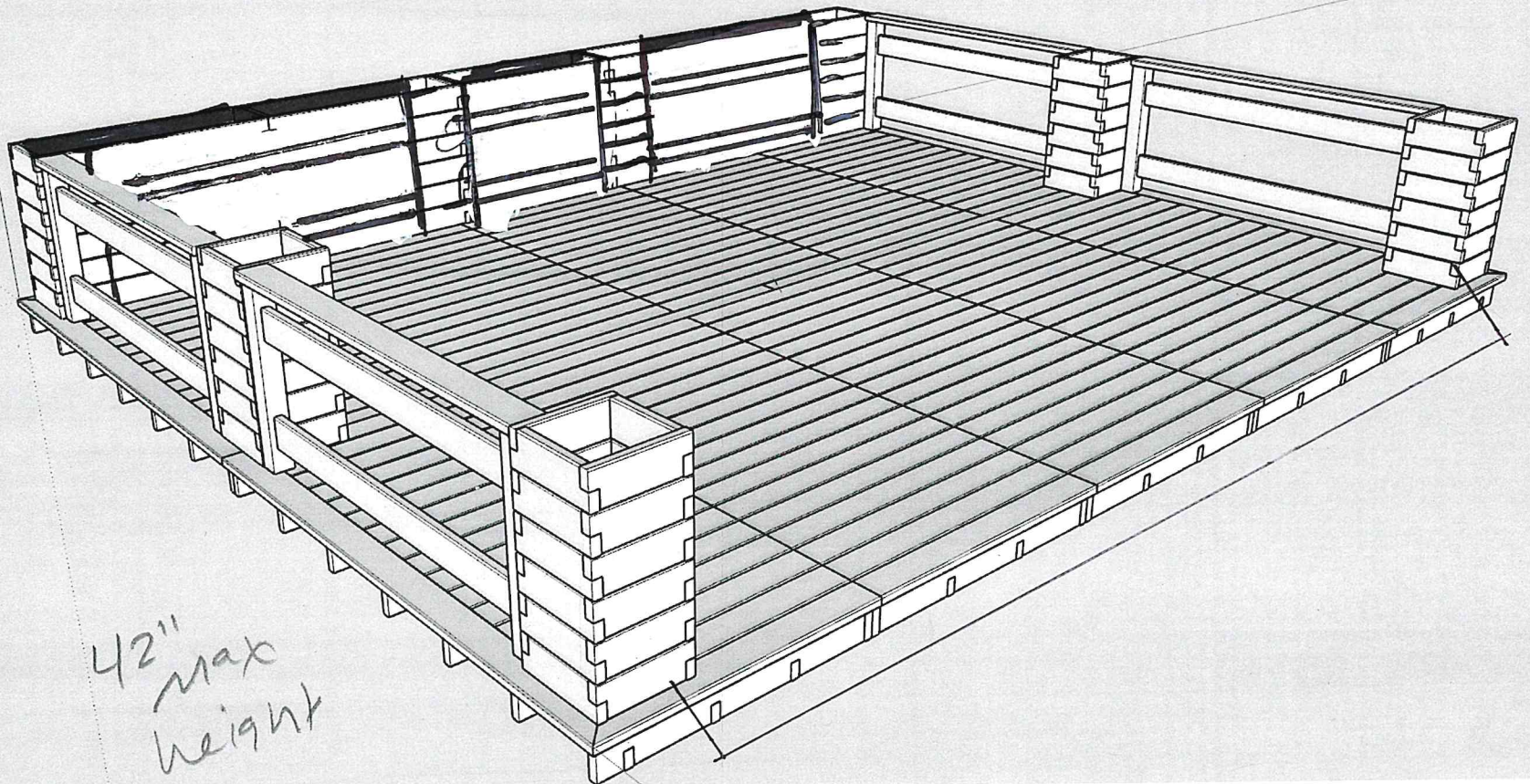

42"  
max  
height

Showing sides of parklet

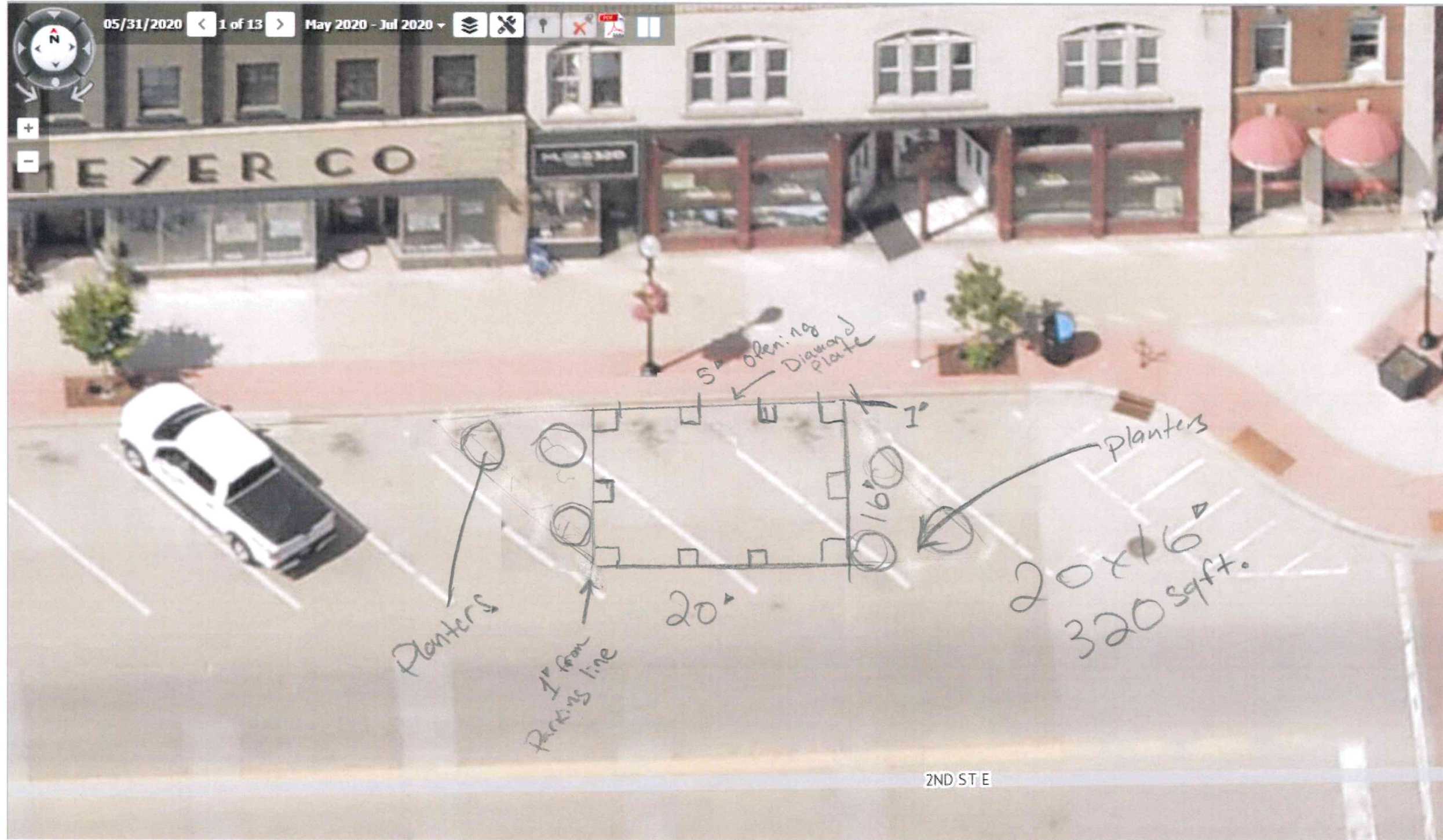



## IX-01 & X-C-01



-Per email correspondence with applicant “We will be adding corner benches to a structure wedding tables on the other end with chairs see attached pictures for reference” – EAH 23 March 2021



- Submitted 11 Mar 2021 IX-01 & X2C-01  
 - missing COI & sketch EMM  
 - spoke w/ Wendy

**Sidewalk Cafe  
 Renewal Application**  
 City Code Chapter 90.16



15 Mar 2021  
 - received COI & sketch - EMM

**Contact Information**

BUSINESS INFORMATION	Name: Taproot LLC dba Onion Grille
	Address: 100 Bibley St
	Phone: 651-437-7577

APPLICANT INFORMATION	Name: Wendy Dodge
	Phone: 651-233-9182
	Address: 109 1/2 2nd St E - Hastings
	Email: oniongrille@gmail.com

**Will the sidewalk café setup be the same as the 2019 setup?**

NO If there has not been any changes to the sidewalk café, please submit proof of insurance and sign the ordinance review form and application.

YES If there has been changes to the sidewalk café, please complete the application and submit the required documents and fee listed in the 'Application Checklist' section.

adding more tables EMM 11 Mar 2021

**Sidewalk Café Description**

Street Name	Length x Width	Number of tables	Number of Seats
Bibley	50 long 7 wide	6-8	20-24
	6'7" 11 Mar 2021 - per Wendy EMM		

Days and Hours of sidewalk café operation:

\* Depends on social distancing guidelines

Describe any entertainment or music:  
 - possibly acoustic

Will alcoholic beverages for consumption be offered in the sidewalk café? NO \_\_\_ YES   
 (If yes, please complete the next section.)

**Sidewalk Café Area to Serve Alcohol (Liquor License Amendment)**

Will alcoholic beverages be served in the entirety of the sidewalk café? NO \_\_\_ YES   
 If no, specify where alcohol will be served?

Days and Hours of alcohol service: Preliminarily Wed-Sat 4pm - 10pm

Has staff received required alcohol training: NO \_\_\_ YES

Procedure ensuring alcohol will be contained in café:  
 staff will monitor

11 Mar 2021  
 - per conversation w/ Wendy EMM  
 on occasion applicant indicated she would contact us when there is music.

## Application Checklist

	Application Form
X	Proposed sidewalk café diagram including furniture specifications; if applicable, specify area to serve alcohol
X	Food and beverage menu
X	Proposed sound or entertainment
X	Ordinance Review Form
X	Proof of insurance. <i>All proofs of insurance must include in the description:</i> <ul style="list-style-type: none"> <li>• City of Hastings is included as an additional insured. A 10-day cancellation notice is included as part of the policy.</li> </ul> <i>If serving alcohol, the following must be included in the description:</i> <ul style="list-style-type: none"> <li>• Coverage extends to adjacent sidewalk and off premises events.</li> </ul>
X	\$50.00 Site Modification Fee; Required if there are any modifications to the Sidewalk Cafe

## Data Practices Notice

Every city in Minnesota must comply with the Minnesota Government Data Practices Act (MGDPA), which, in conjunction with other state and federal laws, classifies all government data. Government data are classified in different categories depending on whether they are accessible by the public.

Government data means all data collected, created, received, maintained or disseminated by the City regardless of its physical form, storage media or conditions of use. There is a presumption that government data are public and are accessible by the public for inspection and copying unless there is a federal law, state statute or temporary classification of data that provides differently.

The data supplied in this application will be used to assess the qualifications for a license. This data is not legally required but the City will not be able to grant the license without it. If a license is granted, the data will constitute a public record. The data is needed to distinguish this application from others, to identify this application in city license files, to verify the identity of the applicant, to contact the applicant if additional information is required and to determine if the applicant meets all ordinance requirements.

*I hereby certify that all statements made in this application are true and complete and understand that any misstatements or omissions of material facts may result in disqualification or denial of the license. I agree to abide by the provisions of this application and all applicable City polices and ordinances.*

Signature:

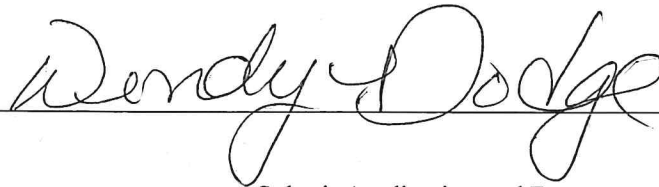

Date:



Submit Application and Fees to:

Erica Henderson  
Deputy City Clerk

101 4<sup>th</sup> Street East  
Hastings, MN 55033

[ehenderson@hastings.mn.gov](mailto:ehenderson@hastings.mn.gov)

651-480-2343

**City of Hastings  
Acknowledgement of  
Review of Ordinance**

I hereby acknowledge that I have read, understand and agree to abide by the regulations set forth in the City's Ordinance associated with the license for which I am applying. Furthermore, I also understand that I must comply with the provisions of all applicable state laws.

Wendy Dodge  
Applicant Signature

3/11/21  
Date

# Onion Grille Sidewalk Cafe

opening/plantance  
per conversation w/ wency  
15 Mar 2021

Sibley St

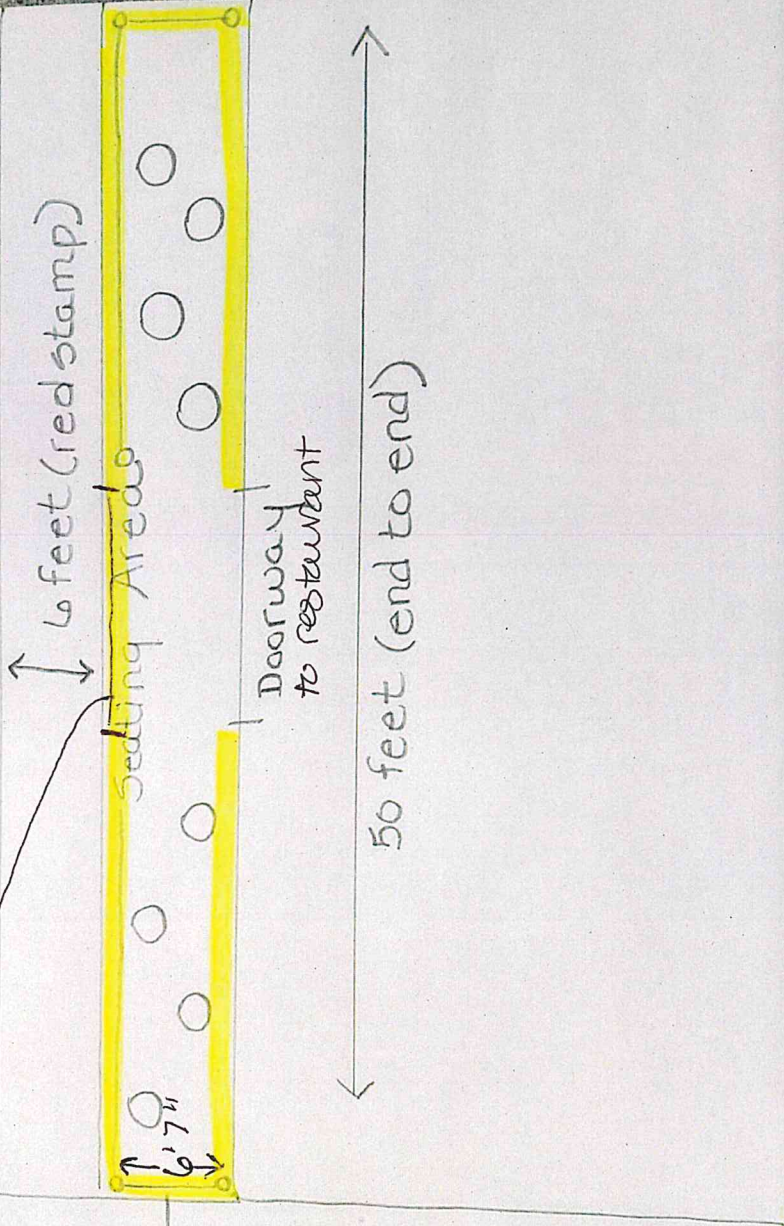

# the pots/planters  
 on either side of  
 the doorway will be  
 removed to increase  
 the size <sup>length</sup> of the  
 sidewalk cafe and  
 the width is being  
 increased to the  
 red colored  
 concrete - BM  
 15 Mar 2021

Fencing

Alley

# New Parklet Application

City Code Chapter 90.17

## Fees:

_____ License	\$100.00
_____ Liquor License <i>(If serving liquor in the parklet)</i>	\$50.00



## Contact Information

BUSINESS INFORMATION	Name:
	Address:
	Phone:

CONTACT PERSON INFORMATION	Name:
	Phone:
	Address:
	Email:

## Parklet Description

Days of Parklet Operation:	Hours of Parklet Operation:
Description of all points of access between the building and the parklet and exterior areas.	
Describe the fencing/barrier to denote parklet area.	
Description of ingress and egress arrangements including those necessary to provide handicap accessibility and to ensure safety of moveable seating arrangements.	
Description of all physical improvements to be constructed to accommodate the parklet.	
Describe any entertainment or music.	
Describe any additional lighting.	

Any other information and details:

Will alcoholic beverages for consumption be offered in the parklet? NO \_\_\_\_ YES \_\_\_\_  
*(If yes, please complete the next section.)*

**Parklet to Serve Alcohol (Liquor License Amendment)**

Will alcoholic beverages be served in the entirety of the parklet? NO \_\_\_\_ YES \_\_\_\_  
*If no, specify where alcohol will be served?*

Days and hours of alcohol service:

Has staff received required alcohol training: NO \_\_\_\_ YES \_\_\_\_

Procedure ensuring alcohol will be contained in parklet:

**Other Required Documents**

- Parklet diagram
  - Refer to City Code Section 90.17(G)(2)(a) for required diagram specifications
- Photographs and manufacturer specifications for all proposed parklet furniture and fixtures.
- Certificate of Insurance
  - All proofs of insurance must include in the description:*
    - City of Hastings is included as an additional insured. A 10-day cancellation notice is included as part of the policy.
    - If serving alcohol, the following must be included in the description:* Coverage extends to adjacent sidewalk and off premises events.
- Food and Beverage Menu

**Application Checklist**

	Application Form
	Proposed parklet diagram including furniture specifications.
	Food and beverage menu
	Proposed sound or entertainment
	Ordinance Review Form
	Certificate of insurance. <i>All proofs of insurance must include in the description:</i> <ul style="list-style-type: none"> <li>• City of Hastings is included as an additional insured. A 10-day cancellation notice is included as part of the policy.</li> </ul> <i>If serving alcohol, the following must be included in the description:</i> <ul style="list-style-type: none"> <li>• Coverage extends to adjacent sidewalk and off premises events.</li> </ul>
	\$100.00 Application Fee
	\$50.00 Liquor License Amendment Fee (if applicable)

**Data Practices Notice**

Every city in Minnesota must comply with the Minnesota Government Data Practices Act (MGDPA), which, in conjunction with other state and federal laws, classifies all government data. Government data are classified in different categories depending on whether they are accessible by the public.

Government data means all data collected, created, received, maintained or disseminated by the City regardless of its physical form, storage media or conditions of use. There is a presumption that government data are public and are accessible by the public for inspection and copying unless there is a federal law, state statute or temporary classification of data that provides differently.

The data supplied in this application will be used to assess the qualifications for a license. This data is not legally required but the City will not be able to grant the license without it. If a license is granted, the data will constitute a public record. The data is needed to distinguish this application from others, to identify this application in city license files, to verify the identity of the applicant, to contact the applicant if additional information is required and to determine if the applicant meets all ordinance requirements.

*I hereby certify that all statements made in this application are true and complete and understand that any misstatements or omissions of material facts may result in disqualification or denial of the license. I agree to abide by the provisions of this application and all applicable City polices and ordinances.*

Signature: \_\_\_\_\_



Date: \_\_\_\_\_

Submit Application and Fees to:  
 Erica Henderson  
 Deputy City Clerk  
 101 4<sup>th</sup> Street East  
 Hastings, MN 55033  
[ehenderson@hastings.mn.gov](mailto:ehenderson@hastings.mn.gov)  
 651-480-2343



**City of Hastings  
Acknowledgement of  
Review of Ordinance**

I hereby acknowledge that I have read, understand and agree to abide by the regulations set forth in the City's Ordinance associated with the license for which I am applying. Furthermore, I also understand that I must comply with the provisions of all applicable state laws.

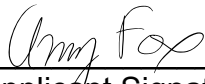
  
\_\_\_\_\_  
Applicant Signature

\_\_\_\_\_  
Date

Spiral Brewery Parklet  
Drawings/Specs, Menu and Furniture Specs

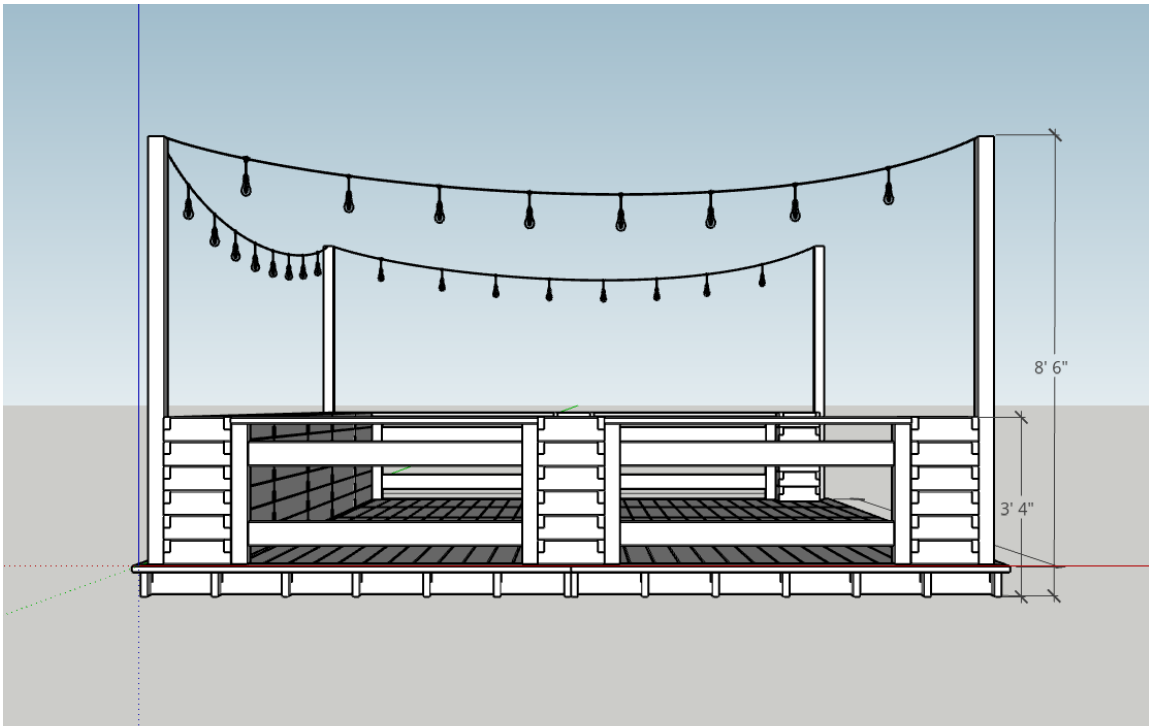
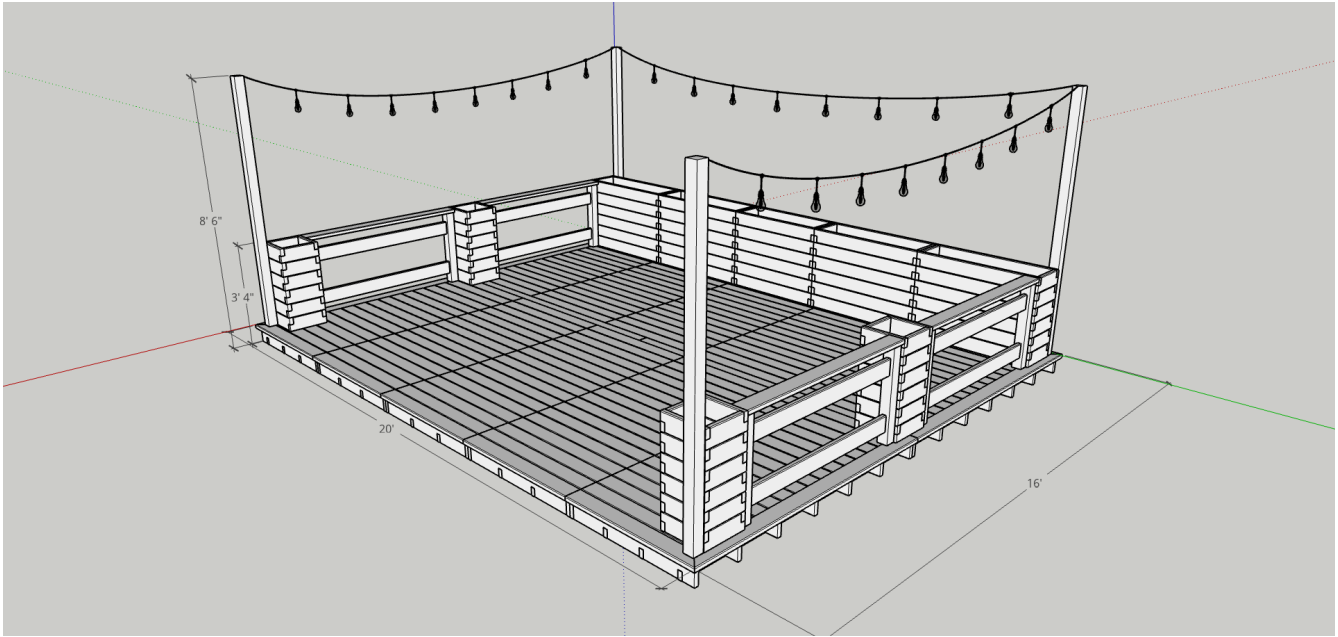

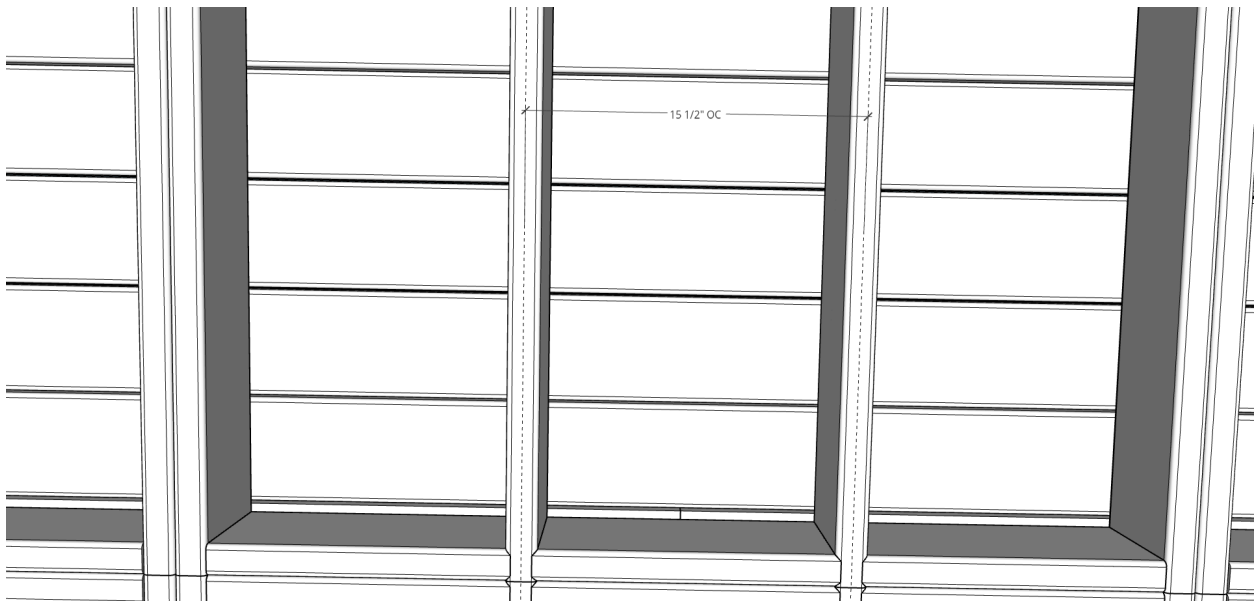
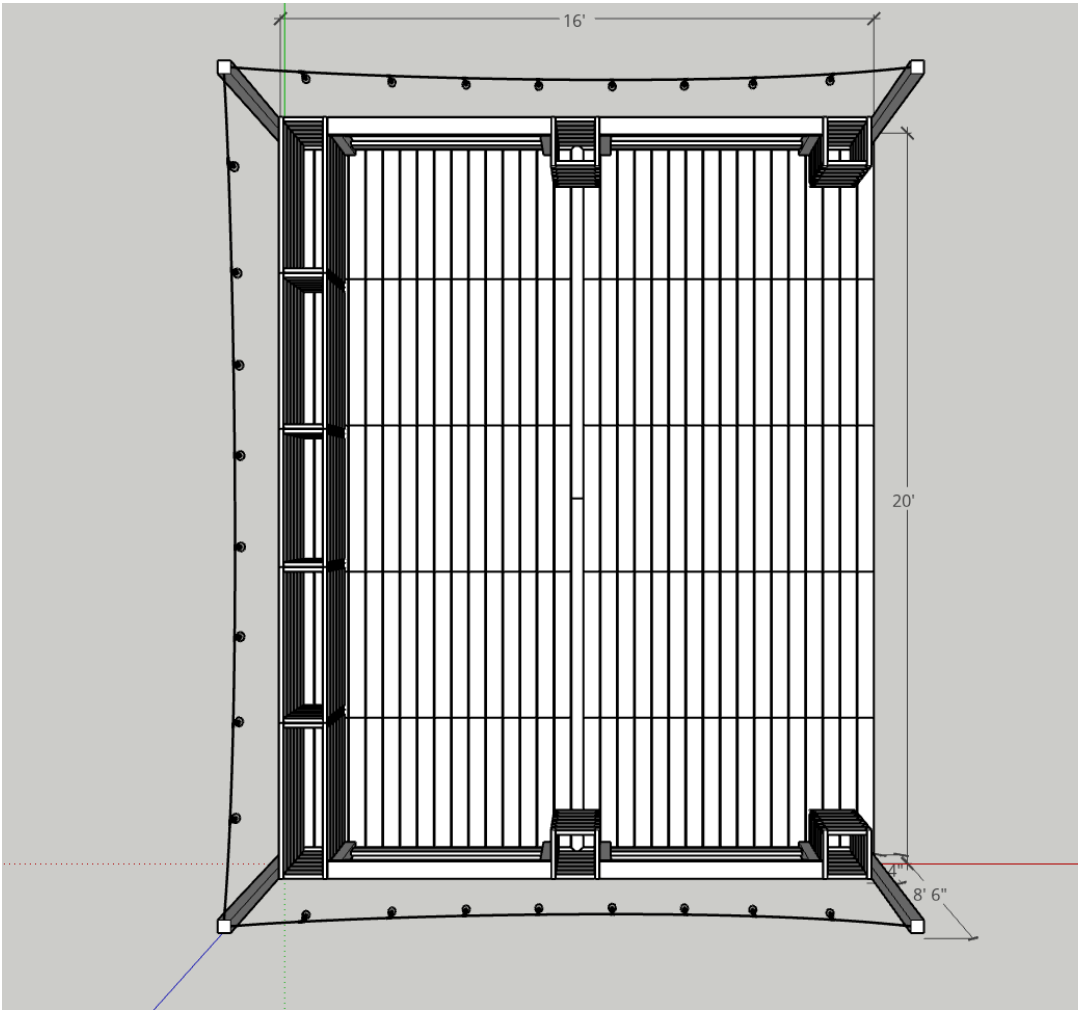

Truss dimension

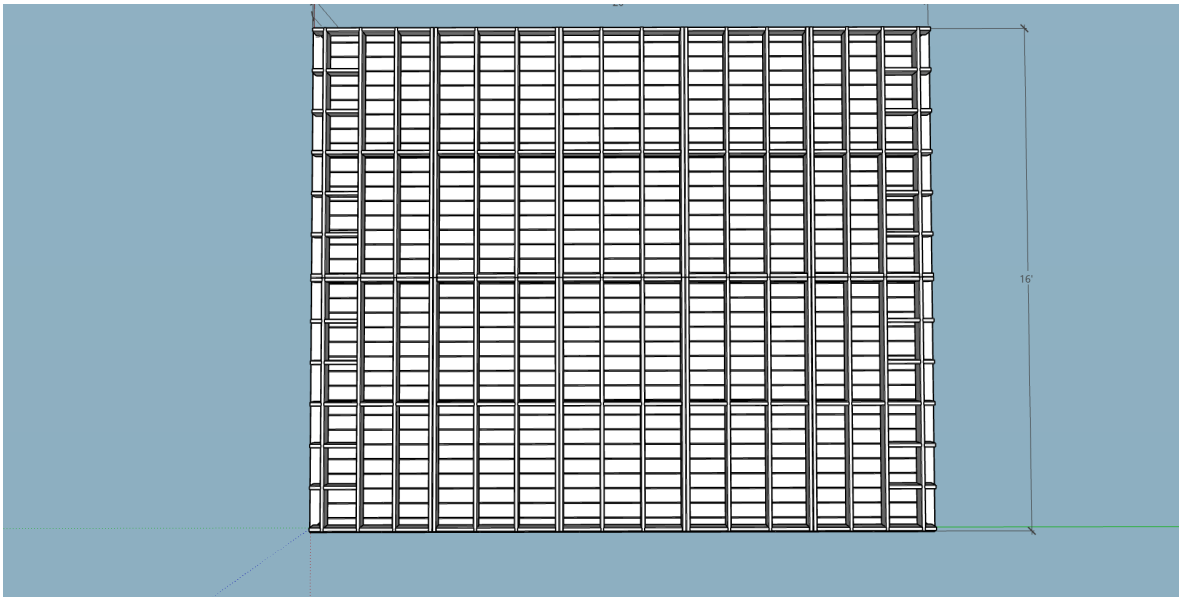

### Truss underside

Here is a list of the main materials:

- Base truss lattice - AC2 treated pine boards
- Decking, Planters, and railings - untreated douglas fir
- Finish - Seal-Once Premium Marine wood sealer
- Hardware - Coated Decking Screws, black-coated steel post brackets and planter supports, Galvanized Carriage bolts (where applicable)
- Accessibility Sill plate provided - 1/8" sheet aluminum

### Menu

- Beer brewed on-site
- Kombucha, coffee, canned pop and water
- Pre-packed snacks: flavored pretzels, cheese and meat/cheese sticks and trays
- Food that people are allowed to bring into our establishment

Furniture specs - same as sidewalk cafe



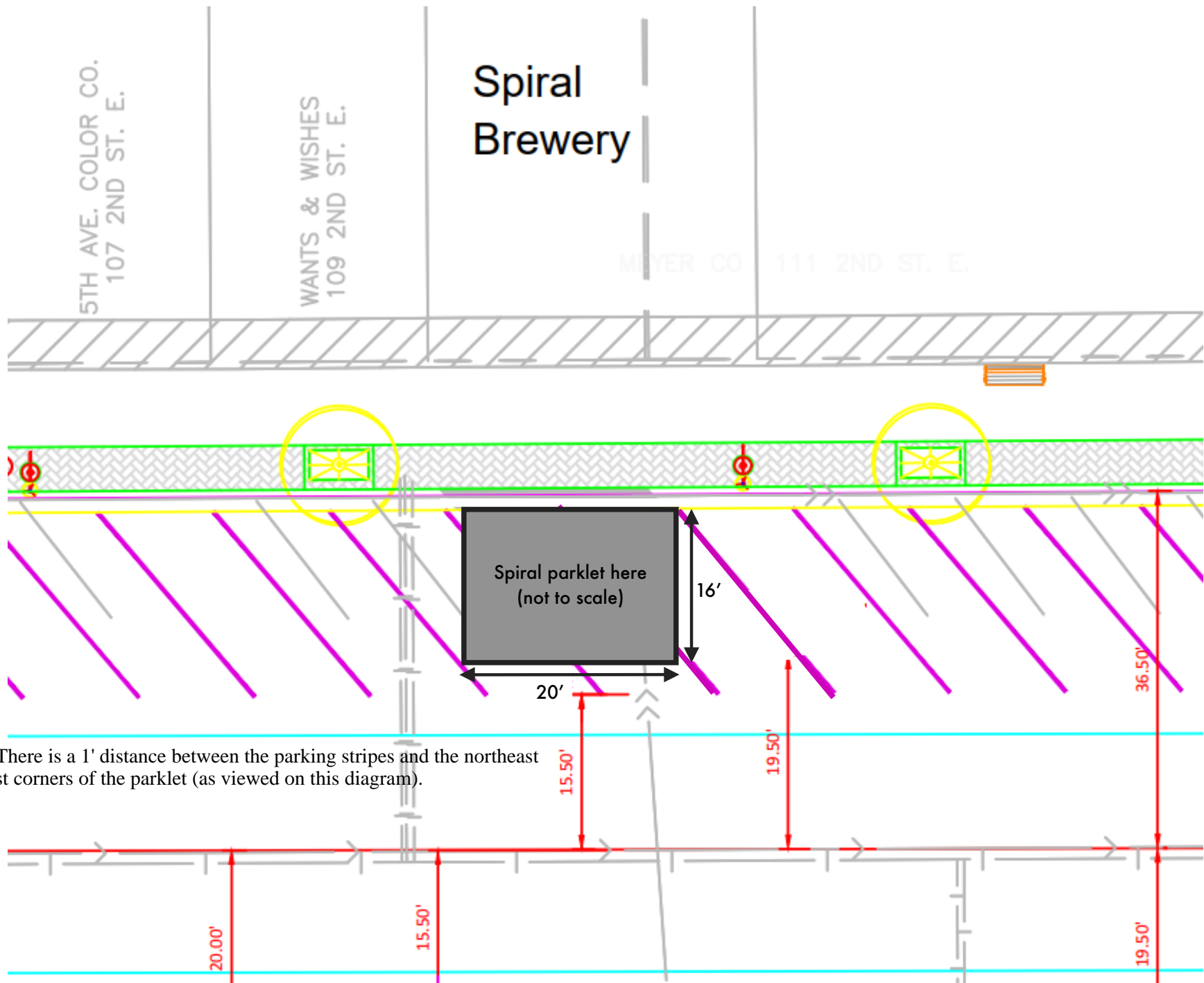

Please note: There is a 1' distance between the parking stripes and the northeast and southwest corners of the parklet (as viewed on this diagram).

**New Parklet Application**

City Code Chapter 90.17



**Fees:**  
 License \$100.00  
 Liquor License \$50.00  
*(If serving liquor in the parklet)*

**Contact Information**

BUSINESS INFORMATION	Name: The Busted Nut Bar & Grill
	Address: 118 2nd St. E. Hastings
	Phone: 651 438 6887

CONTACT PERSON INFORMATION	Name: TATIA Nelson
	Phone: 651 438 6887
	Address: 118 2nd St. E. Hastings
	Email: thebustednut@comcast.net

**Parklet Description**

Days of Parklet Operation: 7	Hours of Parklet Operation: 11AM-11PM
Description of all points of access between the building and the parklet and exterior areas. Single point of access from building (front), patrons will cross sidewalk to enter parklet will not be on street surface or enter traffic	
Describe the fencing/barrier to denote parklet area. Rail fence attached to planter boxes around perimeter of platform - See attached photo	
Description of ingress and egress arrangements including those necessary to provide handicap accessibility and to ensure safety of moveable seating arrangements. Aluminum tread plate to be installed between curb and platform to eliminate any gaps	
Description of all physical improvements to be constructed to accommodate the parklet. See attached literature	
Describe any entertainment or music. Piped in music at soft volume for background music	
Describe any additional lighting. Patio String lights to be hung from 4x4 posts attached to planter boxes	

5 March 2021  
 \*per email correspondence with T. Nelson  
 Speakers are closest to sidewalk cafe  
 no cords will be running on the sidewalk to parklet - they will be strung/hung from above - she wants to avoid any tripping hazards  
 -EM

Any other information and details:

piped in music at soft volume  
for background music outside.

Will alcoholic beverages for consumption be offered in the parklet? NO \_\_\_ YES  \_\_\_  
(If yes, please complete the next section.)

**Parklet to Serve Alcohol (Liquor License Amendment)**

Will alcoholic beverages be served in the entirety of the parklet? NO \_\_\_ YES  \_\_\_  
If no, specify where alcohol will be served?

Days and hours of alcohol service: 11am-11pm

Has staff received required alcohol training: NO \_\_\_ YES  \_\_\_

Procedure ensuring alcohol will be contained in parklet:

Fenced in area  
staff present at all times as well  
as trained.

**Other Required Documents**

-Parklet diagram

-Refer to City Code Section 90.17(G)(2)(a) for required diagram specifications

-Photographs and manufacturer specifications for all proposed parklet furniture and fixtures.

-Certificate of Insurance

All proofs of insurance must include in the description:

-City of Hastings is included as an additional insured. A 10-day cancellation notice is included as part of the policy.

If serving alcohol, the following must be included in the description: Coverage extends to adjacent sidewalk and off premises events.

-Food and Beverage Menu

**Application Checklist**

	Application Form
	Proposed parklet diagram including furniture specifications.
	Food and beverage menu
	Proposed sound or entertainment
	Ordinance Review Form
	Certificate of insurance. <i>All proofs of insurance must include in the description:</i> <ul style="list-style-type: none"> <li>• City of Hastings is included as an additional insured. A 10-day cancellation notice is included as part of the policy.</li> </ul> <i>If serving alcohol, the following must be included in the description:</i> <ul style="list-style-type: none"> <li>• Coverage extends to adjacent sidewalk and off premises events.</li> </ul>
	\$100.00 Application Fee
	\$50.00 Liquor License Amendment Fee (if applicable)

**Data Practices Notice**

Every city in Minnesota must comply with the Minnesota Government Data Practices Act (MGDPA), which, in conjunction with other state and federal laws, classifies all government data. Government data are classified in different categories depending on whether they are accessible by the public.

Government data means all data collected, created, received, maintained or disseminated by the City regardless of its physical form, storage media or conditions of use. There is a presumption that government data are public and are accessible by the public for inspection and copying unless there is a federal law, state statute or temporary classification of data that provides differently.

The data supplied in this application will be used to assess the qualifications for a license. This data is not legally required but the City will not be able to grant the license without it. If a license is granted, the data will constitute a public record. The data is needed to distinguish this application from others, to identify this application in city license files, to verify the identity of the applicant, to contact the applicant if additional information is required and to determine if the applicant meets all ordinance requirements.

*I hereby certify that all statements made in this application are true and complete and understand that any misstatements or omissions of material facts may result in disqualification or denial of the license. I agree to abide by the provisions of this application and all applicable City polices and ordinances.*

Signature: \_\_\_\_\_

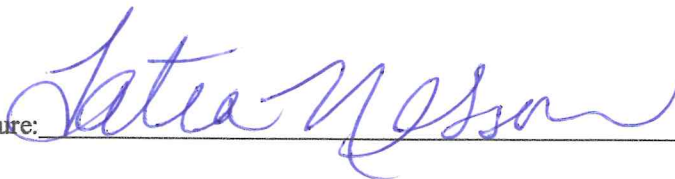

Date: \_\_\_\_\_

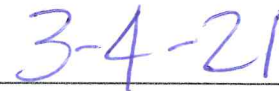

Submit Application and Fees to:

Erica Henderson

Deputy City Clerk

101 4<sup>th</sup> Street East

Hastings, MN 55033

[ehenderson@hastings.mn.gov](mailto:ehenderson@hastings.mn.gov)

651-480-2343



# THE STREETDECK SOLUTION

## KEY BENEFITS

- More affordable than custom designed & fabricated decks
- No skilled labor required for assembly
- Exceptionally low maintenance
- Easy to disassemble and reassemble
- Strong and damage resistant
- Readily scalable in length and width
- Integrated planters, benches, railings and panels
- Completely customizable with 3rd party accessories

Archatrak's 'StreetDeck' is a modular deck kit designed for quick and easy assembly and disassembly in practically any location – pavements, roadway parking spaces or outside restaurants and shops.

Modular decks such as StreetDeck can enable restaurants and cafes to offer areas of additional outdoor seating that not only abide with any social distancing requirements, but provide an attractive and restful place to enjoy the company of others.



# STREET DECK

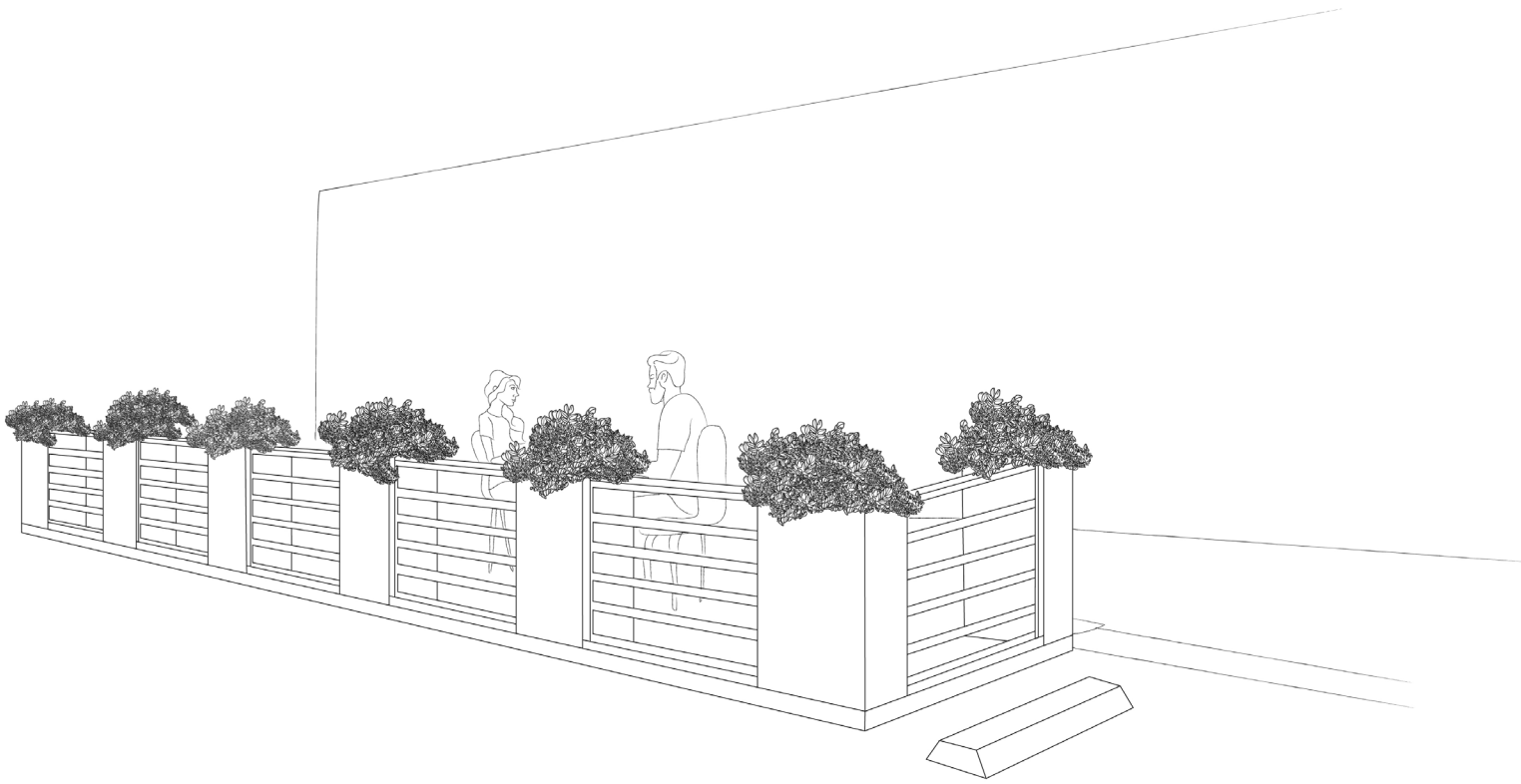

Two-Car StreetDeck

// 6' x 32'

INSTALLATION MANUAL

# TOOLS

Tools needed to assemble StreetDeck

# IX-01 & X-C-01

## 1 Hex key

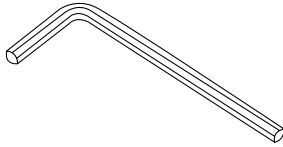

Use hex key with hex socket bolts to secure ramp to ramp brackets and to attach planters to mounting brackets with rivnuts.

## 2 Socket wrench (10mm)

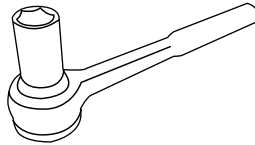

Use socket wrench for nuts on carriage bolts. Power Drill with adapter can also be used.

## 3 Tape measure



Use tape measure for proper pedestal placement and to check diagonal measurement.

## 4 6' or 8' level

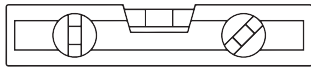

Use level when installing support pedestals and when laying porcelain pavers.

## 5 Hand saw

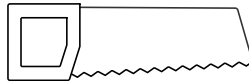

Use hand saw to shorten length of watering pipes in planter boxes. *(If supplied)*

## 6 Tile lifter (optional)

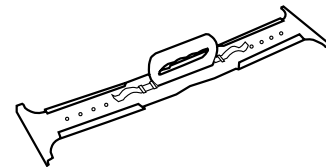

Use tile lifter to remove porcelain pavers from deck when dismantling StreetDeck.

## 7 Box Cutter



Use box cutter to trim tabs off rubber pads.

## 8 Power Drill with 3/8" bit for metal.

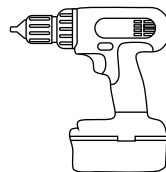

Required for drilling 6 holes into each planter to mount fence panels.

# STREETDECK PERIMETER

## Components

# IX-01 & X-C-01

Assembling  
the StreetDeck  
Perimeter

- A** Perimeter beam 4'W

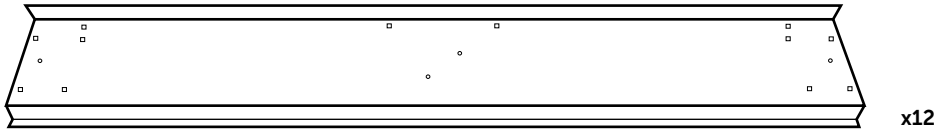

- B** Crossbeam 4'W

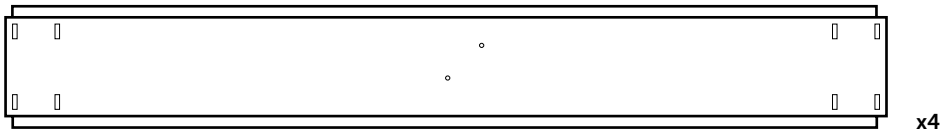

- C** Middle plate

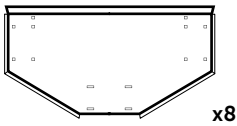

- D** Corner plate

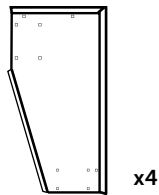

- E** Link bracket

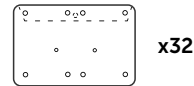

- F** Carriage bolts, nuts & washers

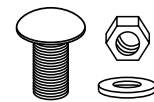

x8 per link bracket

# STREETDECK PERIMETER

## Assembly

- 1** Identify perimeter components. Arrange components in formation of StreetDeck. (see below)

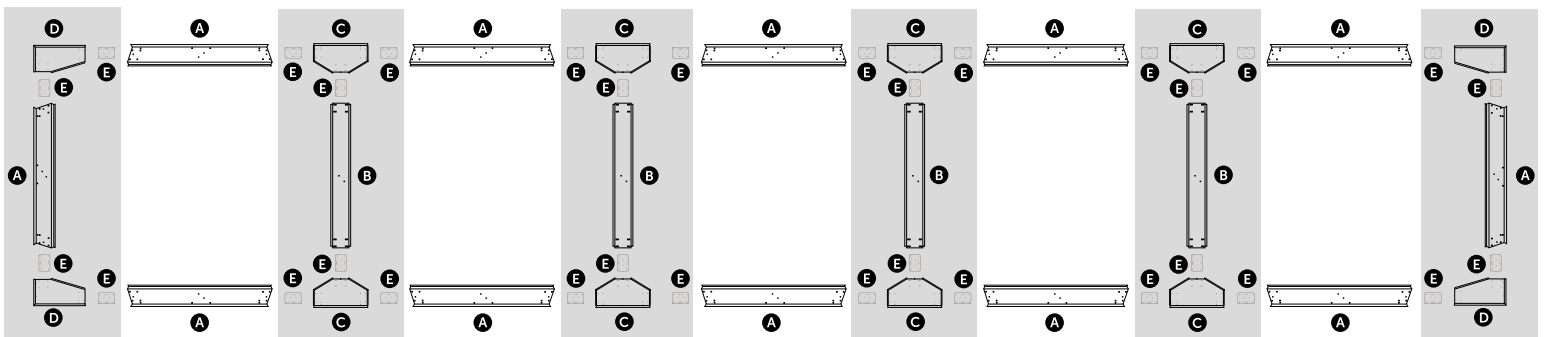

- 2** Begin building sections of the deck indicated by the gray rectangles above. To do so, attach link brackets to crossbeams, middle plates, corner plates and side perimeter beams. Turn each section upside down when connecting the carriage bolts, washers, and nuts to ease the assembly process.

- 3** From there, attach each section to the perimeter beams with the link brackets and carriage bolts.

*For StreetDeck with ramp:*

- G** Support pedestals

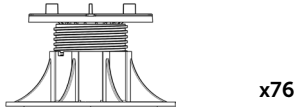

- H** Rubber pads



- I** 24" x 24" porcelain pavers

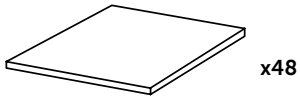

- J** Ramp bracket

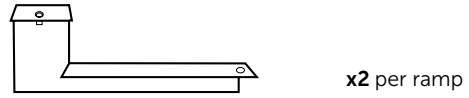

- F** Carriage bolts, nuts & washers

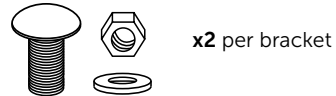

- K** Ramp

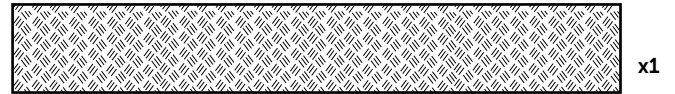

- L** Hex socket bolt

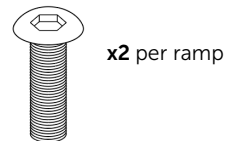

*For StreetDeck with planters:*

- M** Planter bracket

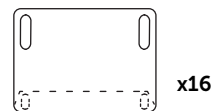

- F** Carriage bolts, nuts & washers

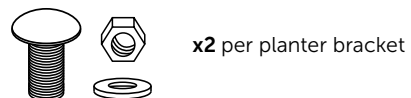

- 1 Decide ramp location and install ramp brackets with protruding end as close to sidewalk as possible. Shift assembled deck closer to sidewalk if necessary.

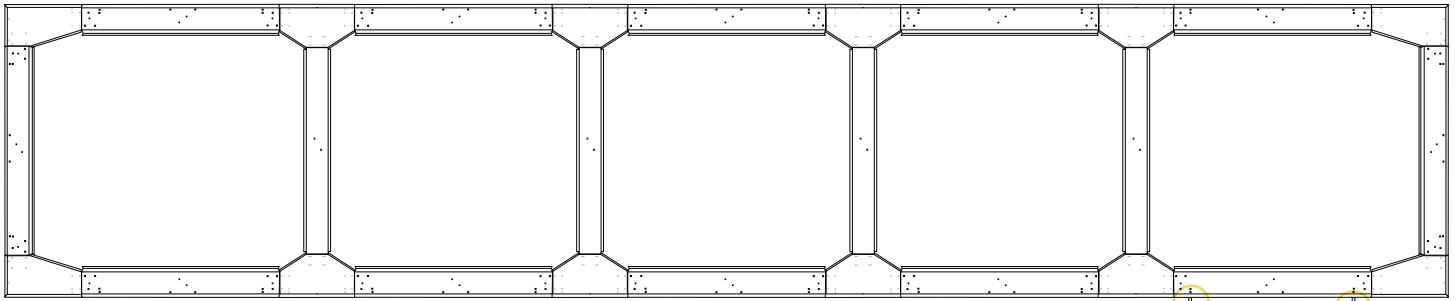

Sidewalk Edge

- 1.1 Use two ramp brackets **1** per ramp. Choose ramp location based on existing holes located on either end of perimeter beam (see above). Use one carriage bolt, washer and nut **2** to attach each ramp bracket to the perimeter beam. Repeat this step if you have more than one ramp. Do not attach ramp to brackets until pavers are laid.



- 2 Square deck frame by measuring distance between diagonal corners and shifting frame as necessary until both measurements are equal.

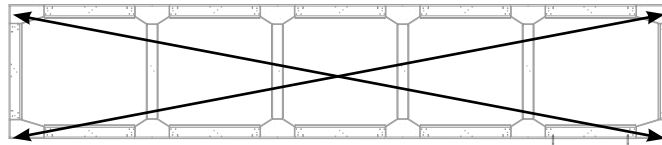

- 3 Use pedestals **6** to elevate StreetDeck perimeter.

Where 'Uptec' pedestals are supplied, the height is adjusted either by inserting a wide screwdriver or supplied tool into the slot in the center of the pedestals and rotating either left or right to raise/lower, or by holding the screwed column firmly and rotating the pedestal base. Extra height is achieved by inserting additional 'collars' between the screwed column and the base. Note that the green ring in the top of the 'Uptec' pedestals should remain loose so the head can move slightly and automatically adjust for the slope of the roadway.

Where 'Eterno' SE pedestals are supplied, the height is adjusted similarly to the Uptec pedestals by rotating the screwed column, but to add extra height, different models of pedestals must be used, each covering a specific height range.

Street Edge

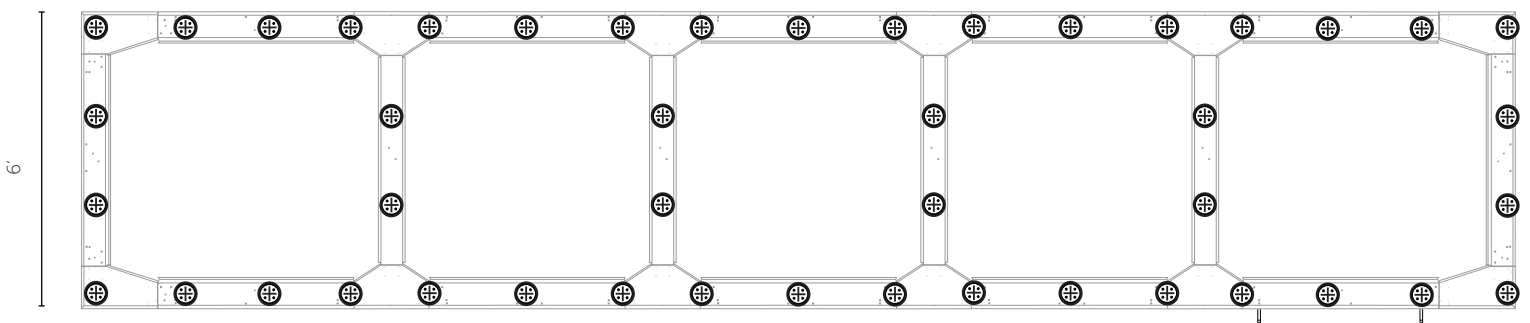

Sidewalk Edge

- 3.1 Begin installation with the row of pedestals along the curb. Cut the plastic base of these curbside pedestals along one of the scored lines on the pedestal base, so the pedestals can sit as close to the curb as possible (subject to any drainage regulations). Snap off the 4 spacer tabs on pedestals used under the perimeter frame so the rubber heads will sit flat on the underside of the steel perimeter. Place pedestals at 24" intervals as shown in the drawing below, adjusting the height so the finished deck will be flush with the level of the pavement.
- 3.2 Lift the steel frame onto the pedestals along the curb side.
- 3.3 Slide remaining pedestals under the frame at 24" intervals as shown, adjusting the height to compensate for the slope of the roadway.
- 3.4 With a spirit level, check for level in all directions and make sure all pedestals are sitting firmly in position under the perimeter, adjusting pedestal heights as necessary.

- 4** Using 2 carriage bolts, washers and nuts **F** per planter bracket **M**, attach planter brackets to perimeter beams in pairs per planter location. Bottom leg of bracket pairs face away from one another, with the exception of bracket in each of the four corners, where the leg faces the bracket it's paired with. *If StreetDeck does not have planters, you may skip this step and go to step 6.*

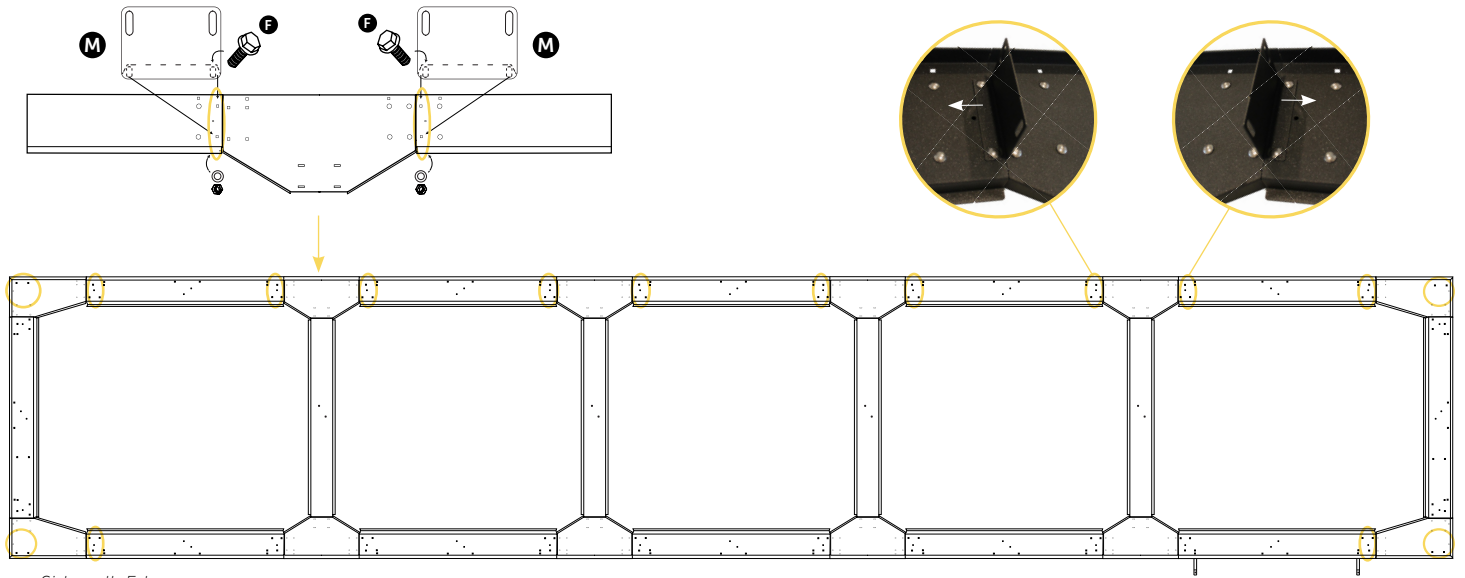

- 5** At all points where the pedestals are under deck frame components, place a rubber pad **H** directly above on surface of frame.

- 5.1** Rubber pads placed at planter bracket location are cut in half, with half going on either side of planter bracket. Make sure the cut pads do not cover any bolt heads.

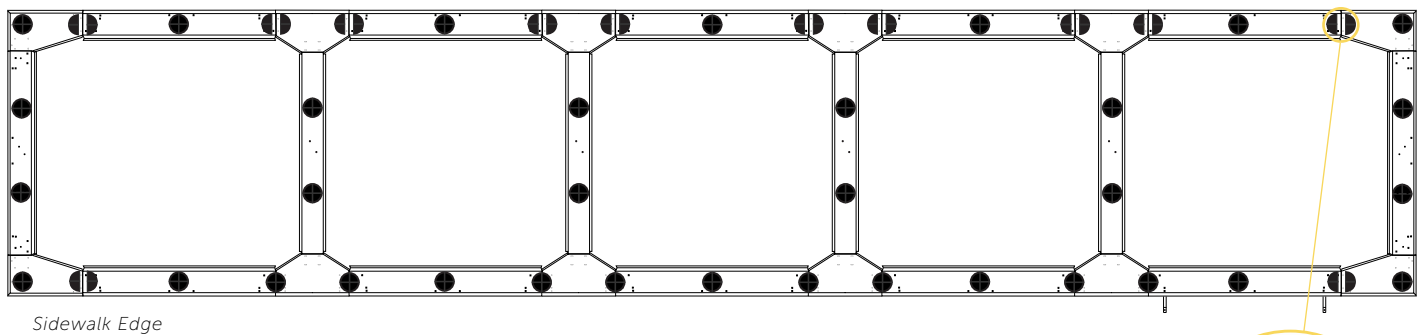

- 5.2** Using a box cutter, remove all 4 spacer tabs on the four pads located in the corners and pads cut in half at planter brackets.

- 5.3** All other rubber support pads require two tabs to be removed. Cut off tabs parallel to the deck frame perimeter.

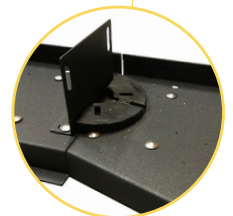
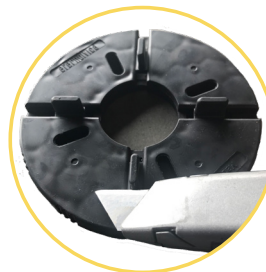

**6** Lay remaining pedestals **G** and porcelain pavers **1**.

**6.1** Lay remaining pedestals at 24" inch spacing as pictured below.

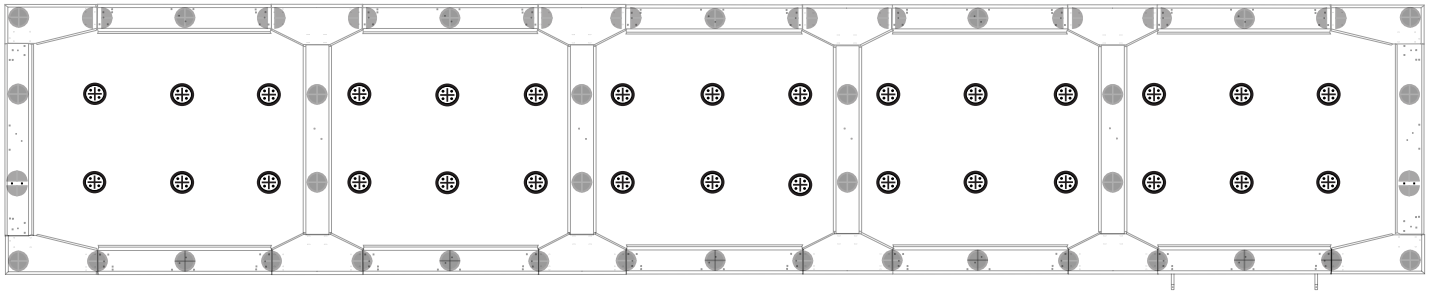

Sidewalk Edge

**6.2** Lay porcelain pavers, one 3-paver row at a time. Position pavers snug against spacer tabs on pedestal heads taking care not to snap off any tabs. Constantly check the deck for level as you lay the pavers, adjusting pedestal heights as necessary.

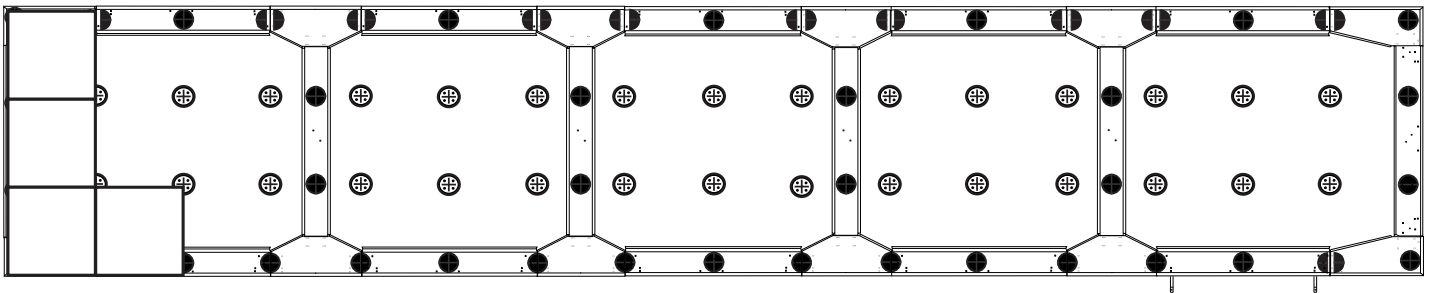

Sidewalk Edge

**6.3** To ensure all pavers fit within the deck frame perimeter, it is critical that the corner of each paver is pressed firmly against the spacer tabs on both the pedestals and the rubber pads, noting that planter brackets (where installed) will protrude from the gaps between the pavers.

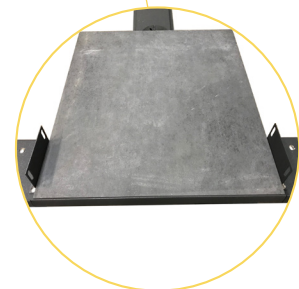
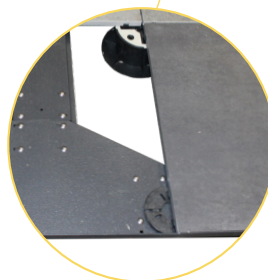
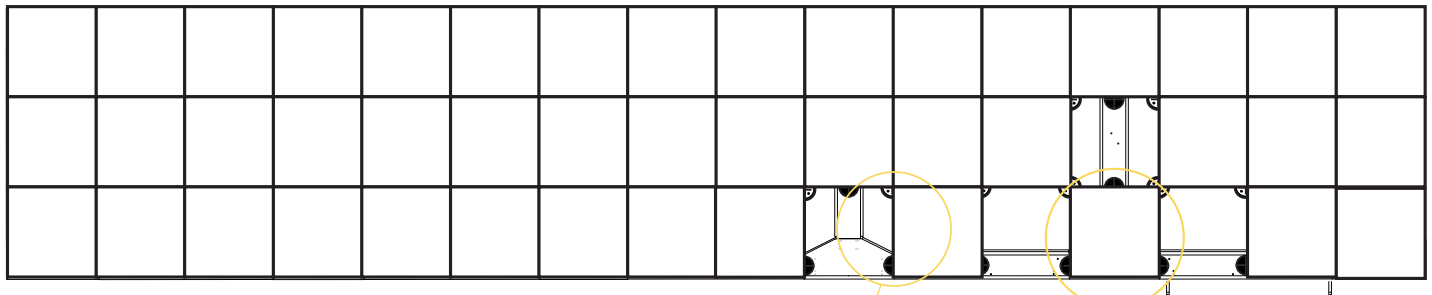



- 7** Using the hex socket bolts **L**, secure the 4' ramp **K** to both ramp brackets **J** with hex key. Repeat this step if using multiple ramps.

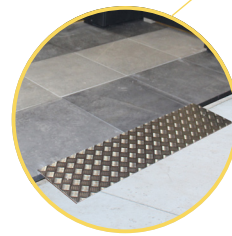
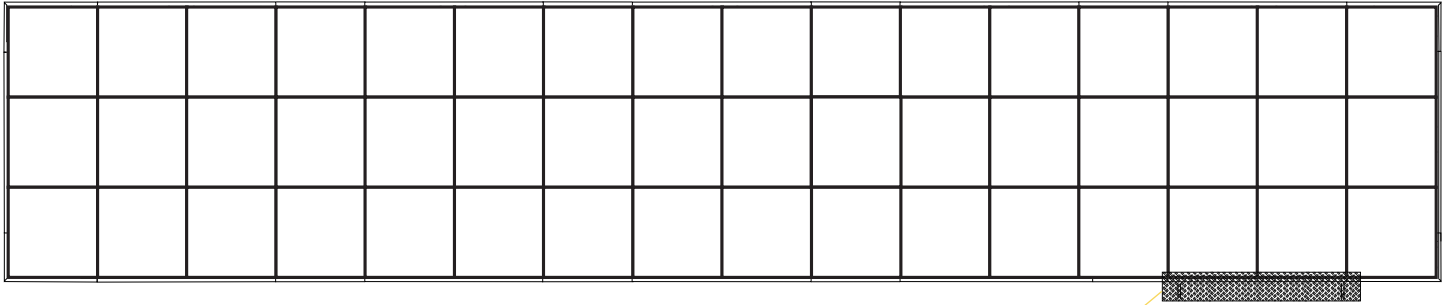

**PLANTERS**

Components

- N** Planter front and back panels  
2'W x 3'H

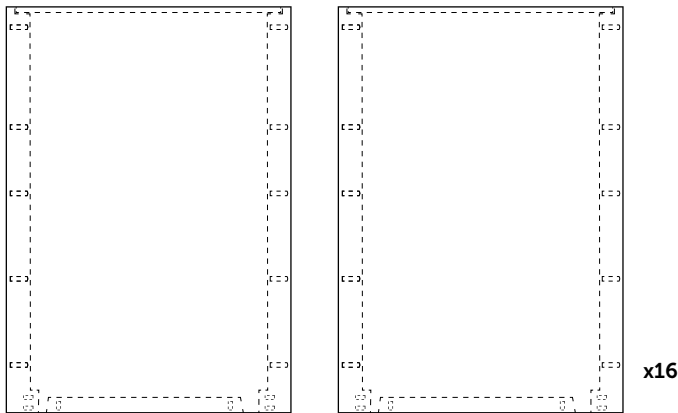

- O** Planter side panels  
1'D x 3'H

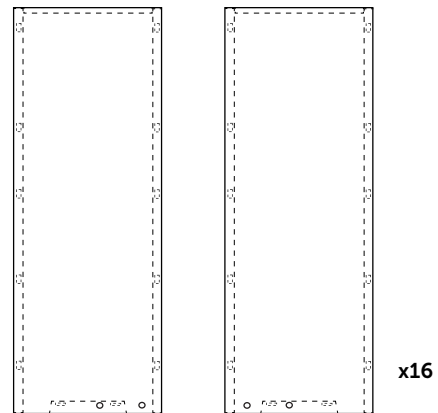

- P** Planter shelf

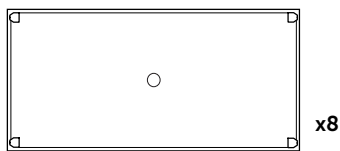

- Q** Rivnuts



- F** Carriage bolts, washer and nuts



- 1 Connect side panels **O** to front and back panels **N**
  - 1.1 Using 20 hex carriage bolts, washers and nuts **F** connect side panels **O** to front and back panels **N**
  - 1.2 Make sure the 2 rivnuts near the bottom of both sides are closest to the same large panel

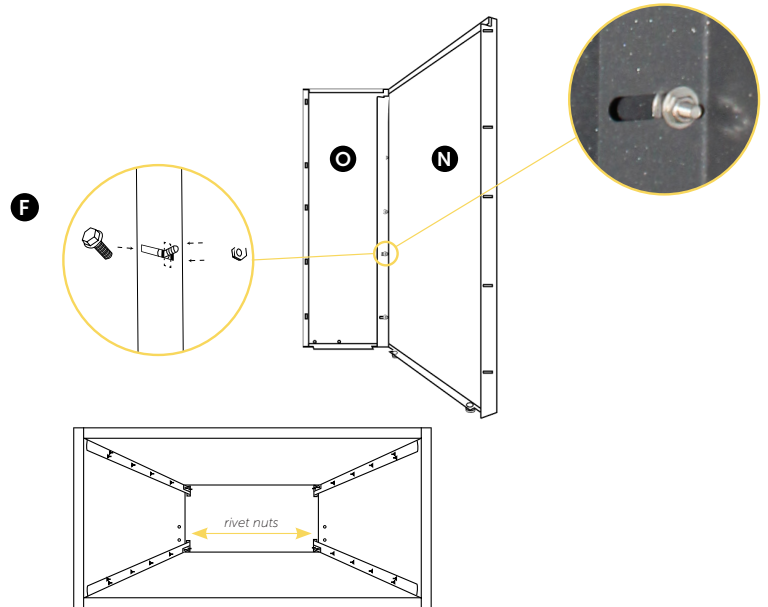

- 2 Insert 4 rubber bumper feet in the four holes on the base of the planter.

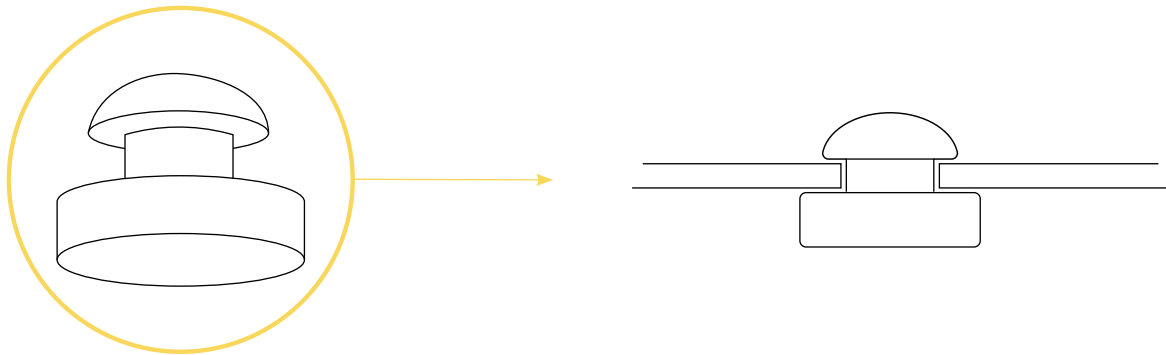

- 3 Stand planter upright. Decide planter shelf height; insert 4 carriage bolts, washers and nuts **F** on innermost side of slot. Rest planter shelf **R** on 4 bolts.

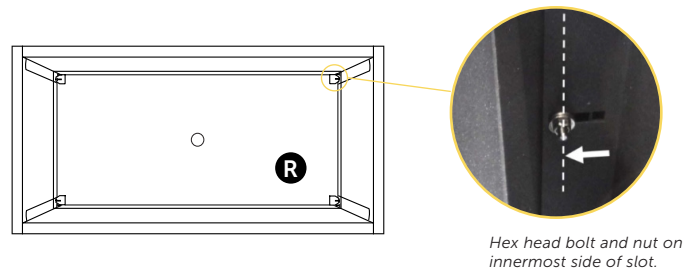

- Secure planters to planter brackets. Use hex key to secure 2 rivnut bolts through each planter bracket into existing rivnuts located near the bottom of the planter side panels.

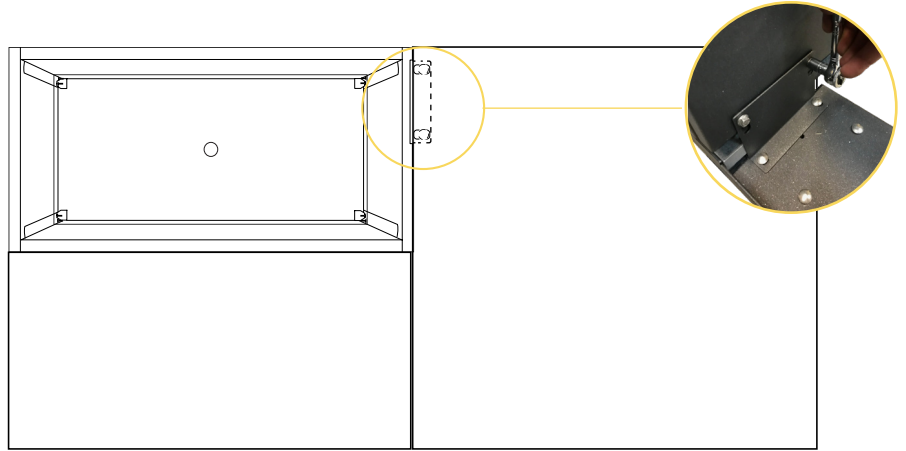

Placement of planters:

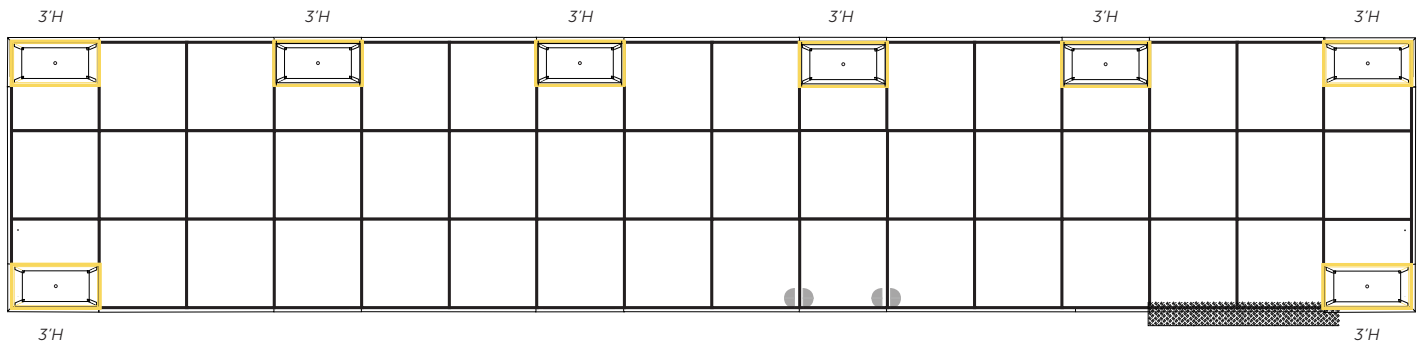

# FENCE

Components

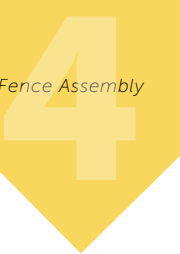

**Y** 4'W x 3'H fence panel

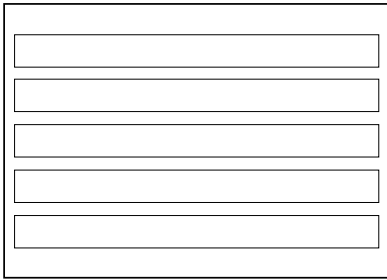

x7

**F** Carriage bolts, washer and nuts



x6 per fence panel

# FENCE

Assembly

**1** Since StreetDeck permits custom fence panels and railings to be used, holes for mounting panels to the planters are not predrilled in the planters.

Using the predrilled holes in the fence panels as a guide, drill 3 x 3/8" dia holes in the sides of the planters 2" (min) from the edge of the planters.

**11** Attach fence panels to planters by fixing in place with 3 carriage bolts, washers and nuts per side.

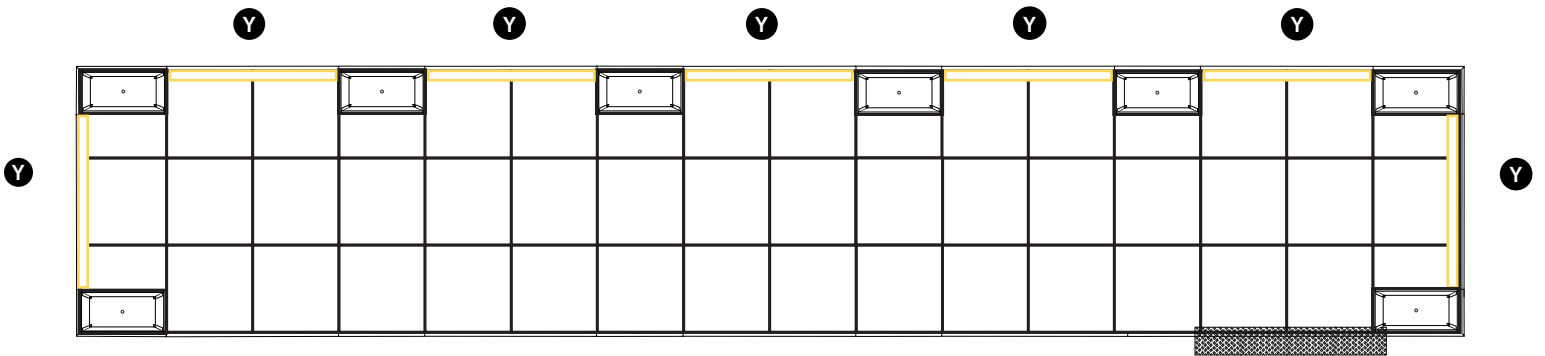
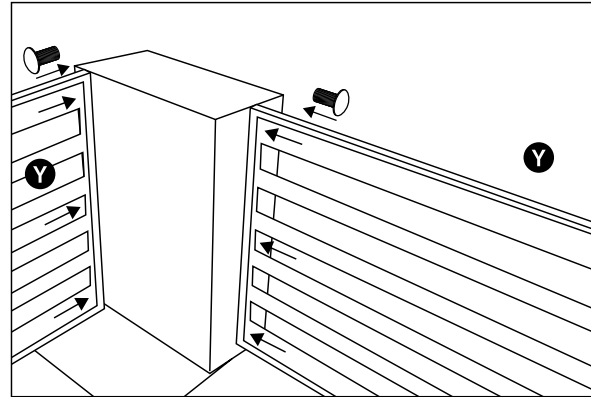

## PLANTER SOIL SACK (where supplied)

### Components

**T** Soil sack

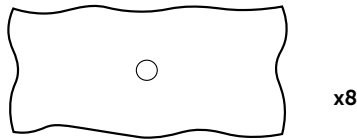

**U** Drain hose

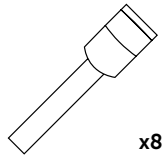

**V** Insulation panels

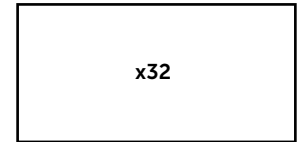

**W** Watering pipe



**X** Filter fabric



## PLANTER SOIL SACK

### Installation

- 1 Position the insulation panels **V** against inside face of all four planters. Place soil sack **T** with drain hose **U** in planter. Insert drain hose into hole located in the center of the planter shelf. Make sure the soil sack stands upright.

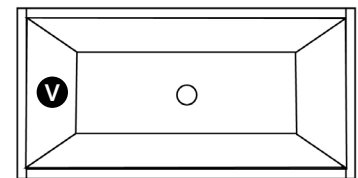
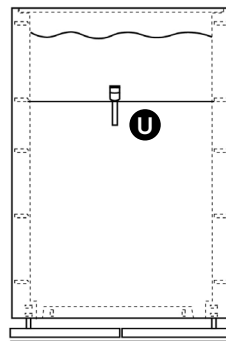
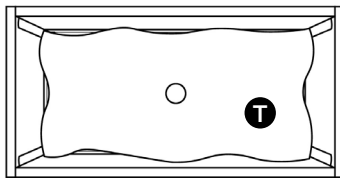

- 2 Place watering pipe **W** in the corner of soil sack. Use hand saw to shorten length of watering pipe if necessary. Cover the drain hole with piece of filter fabric.

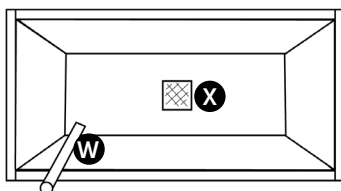

- 3 Fill sack with soil and plant vegetation.

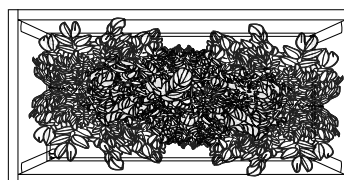

### ⚠ CAUTION

While Archatrak porcelain pavers are exceptionally dense, durable and rigid, they can suffer damage due to mishandling, careless treatment or accidental impact. If hard objects are dropped on the pavers from a significant height, chips, scratches, surface damage and / or cracking and breakage may occur. Where a deck height is greater than 4", especially in high traffic commercial installations, appropriate reinforcement sheets or protective panels should be installed on the underside of the pavers.

See [archatrak.com/break-through-protection](http://archatrak.com/break-through-protection) for further information.

Archatrak Inc.

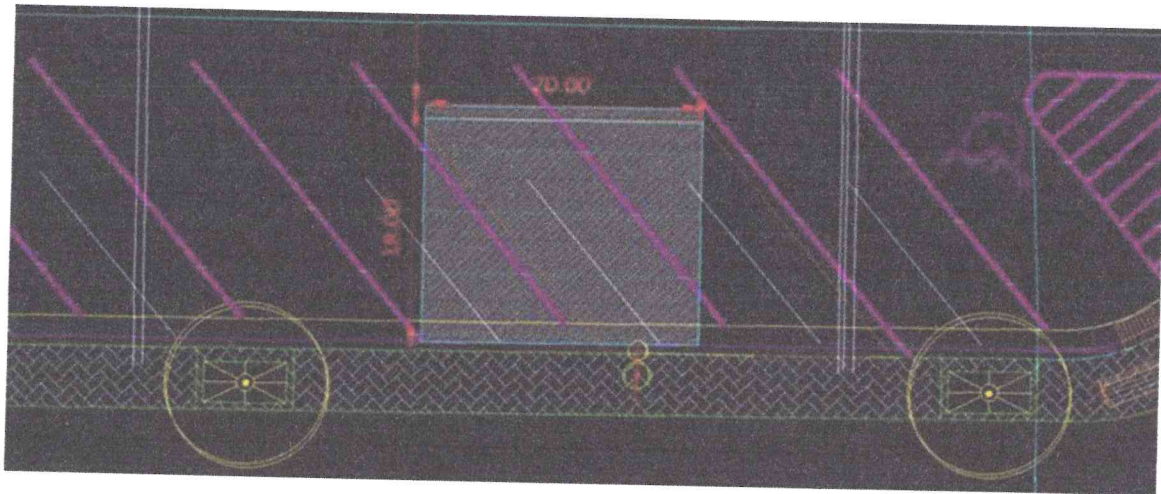

as provided by City Staff

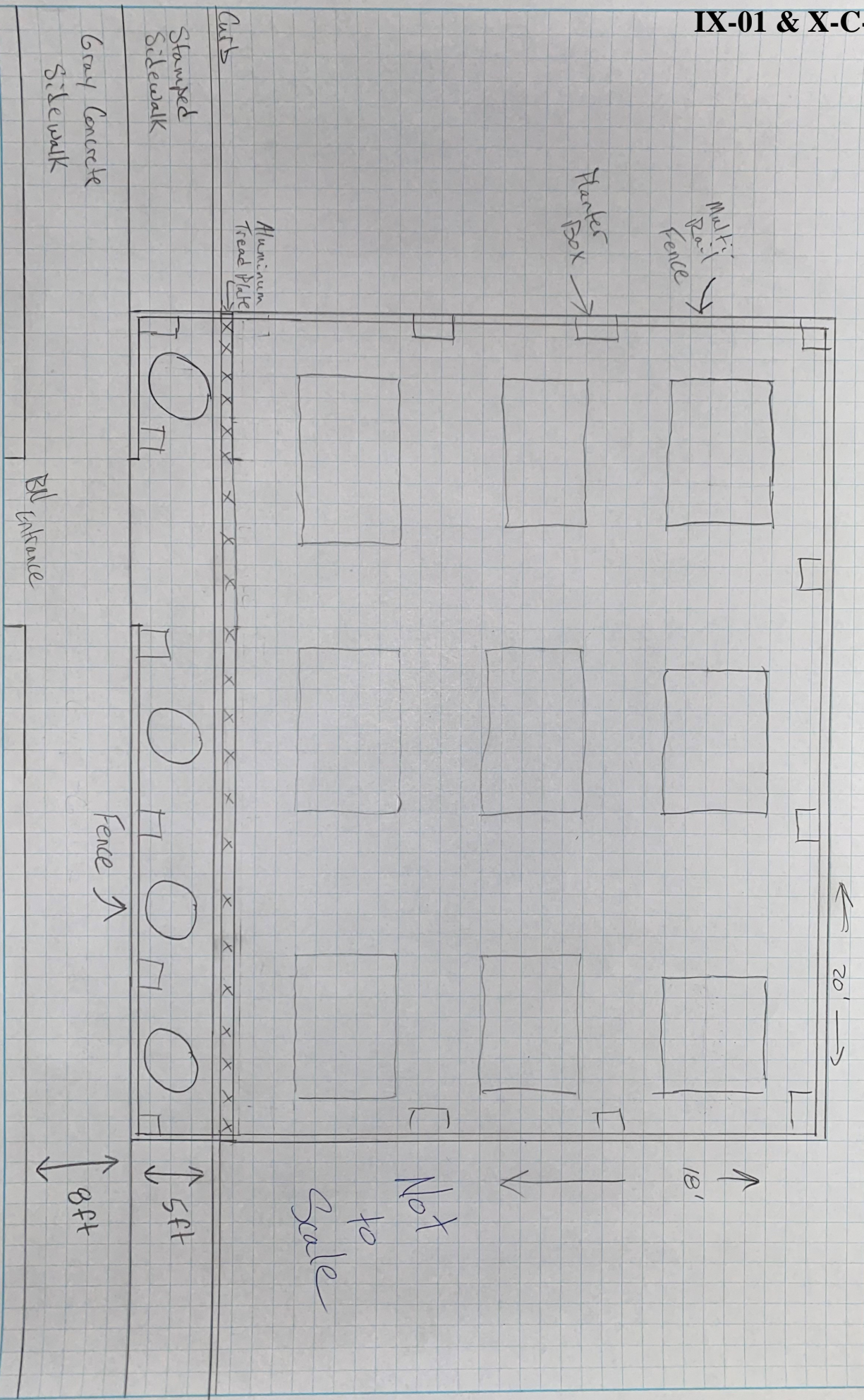

**SIDEWALK CAFÉ LICENSE  
INSURANCE AND INDEMNIFICATION AGREEMENT**

This License Agreement (“Agreement”) is made on April \_\_\_\_, 2021, by and between the City of Hastings, a Minnesota Municipal Corporation with a business address of 101 East 4<sup>th</sup> Street, Hastings, MN 55033 (“the City”), and Nelson-Lucking Post #47, Department of Minnesota, American Legion Incorporated having a registered office address of 50 Sibley Street, Hastings, MN 55033 (“Licensee”).

The City is owner of a platted and improved street and sidewalk right-of-way for Sibley Street as the same is depicted on the plat of the Town of Hastings on file and of record in the Office of the County Recorder, Dakota County, Minnesota (“the Right-of-Way”).

Licensee operates a food and beverage establishment from property located generally at 50 Sibley Street, Hastings, MN 55033 and legally described as Lot One (1) and the East Twenty-four (24) feet of Lot Two (2) except the South Fifteen (15) feet of the West Twelve (12) feet thereof, in Block Four (4) of the Town of Hastings, according to the plat thereof on file and of record in the office of the Register of Deeds, Dakota County, Minnesota (“the Licensed Property”).

Licensee has been granted a license under City of Hastings Ordinance Section 90.16 to operate a Sidewalk Cafe within an identified portion of the public sidewalk or right-of-way immediately adjacent to the Licensed Property (“Sidewalk Cafe License”).

As a condition of the Sidewalk Cafe License, Licensee must comply with the following ordinance requirements:

*All sidewalk cafe licensees must at all times maintain commercial liability insurance covering the licensed premises and the sidewalk cafe area with minimum policy limits for bodily injury or death of not less than \$1,000,000 per occurrence and \$1,000,000 annual aggregate and for property damage of not less than \$50,000. Proof of the required liability insurance shall be in the form of a certificate of insurance or some other form acceptable to the City Attorney and City Clerk. All liability insurance policies required herein shall name the city as any additional insured and shall provide that there shall be no cancellation of the policy for any cause, by the insured or by the insurance company, without first giving 10-days’ written notice to the city, addressed to the City Clerk. Operation of a sidewalk cafe or liquor sales by a licensee without required liability insurance coverage shall be grounds for immediate suspension or revocation of the license. In addition, the licensee shall indemnify and hold harmless the city, the city’s public officials, employees and agents from any loss, costs, damages and expenses arising out of the use, design, operation or maintenance of the sidewalk cafe. These insurance and indemnification requirements shall be memorialized in a license agreement signed by the licensee prior to the initial issuance of the sidewalk cafe license and upon any renewal thereof, but failure of the city and the licensee to execute such a license agreement shall not alleviate the licensee of its insurance and indemnification obligations hereunder.*

**LICENSEE HEREBY AGREES** to be bound by the above insurance and indemnification requirements of City of Hastings Ordinance Section 90.16. Licensee shall indemnify and hold the City, the City’s public officials, employees and agents harmless from and against any and all liability, claims, demands, actions, and causes of action, including expenses and reasonable attorneys’ fees, for personal injuries, property damage, or for loss of life or property resulting from, or in any way connected with, Licensee’s use of the Licensed Property and the Right-of-Way area covered by the Sidewalk Cafe License, or any means of ingress or egress from such premises, except liability for personal injuries, property damages, or loss of life or property caused solely by the negligence of the City. Licensee shall implement procedures to ensure no alcohol is sold or provided to minors or allowed outside of the area subject to the Sidewalk Cafe License.

This Agreement is a condition of the Sidewalk Cafe License and confers no rights or benefits upon Licensee, including the continued right to occupy or conduct business operations within the Right-of-Way. The indemnification provisions of this Agreement shall survive expiration, suspension, revocation and any other termination of the Sidewalk Cafe License.



Dated this 5th day of April, 2021.

**CITY**

**CITY OF HASTINGS, A MINNESOTA  
MUNICIPAL CORPORATION**

By: \_\_\_\_\_  
Mary D. Fasbender, Mayor

*(SEAL)*

By: \_\_\_\_\_  
Erica Henderson, City Clerk

Dated this \_\_\_\_\_ day of \_\_\_\_\_, 2021.

**LICENSEE**

**AMERICAN LEGION POST 47**

By: \_\_\_\_\_  
Roxanne Gerlach

Its: \_\_\_\_\_

**PARKLET LICENSE  
INSURANCE AND INDEMNIFICATION AGREEMENT**

This License Agreement (“Agreement”) is made on April \_\_, 2021, by and between the City of Hastings, a Minnesota Municipal Corporation with a business address of 101 East 4<sup>th</sup> Street, Hastings, MN 55033 (“the City”), and El Mexican Restaurant of Hastings LLC having a registered office address of 10819 Kingsfield Lane, Woodbury, MN 55129 (“Licensee”).

The City is owner of a platted and improved street and sidewalk right-of-way for 2<sup>nd</sup> Street as the same is depicted on the plat of the Town of Hastings on file and of record in the Office of the County Recorder, Dakota County, Minnesota (“the Right-of-Way”).

Licensee operates a food and beverage establishment from property located generally at 119 2<sup>nd</sup> St E, Hastings, MN 55033 and legally described as the West Two-Thirds (2/3) of the South 60 Feet of Lot Eight (8), Block Four (4), Town of Hastings, Dakota County, Minnesota (“the Licensed Property”).

Licensee has been granted a license under City of Hastings Ordinance Section 90.17 to operate a Parklet within an identified portion of the public right-of-way in the street in front of the Licensed Property (“Parklet License”).

As a condition of the Parklet License, Licensee must comply with the following ordinance requirements:

*All parklet licensees must at all times maintain commercial liability insurance covering the licensed premises and the parklet area with minimum policy limits for bodily injury or death of not less than \$1,50,000 per occurrence and \$1,500,000 annual aggregate. Proof of the required liability insurance shall be in the form of a certificate of insurance or some other form acceptable to the City Attorney and City Clerk. All liability insurance policies required herein shall name the city as any additional insured and shall provide that there shall be no cancellation of the policy for any cause, by the insured or by the insurance company, without first giving 10-days’ written notice to the city, addressed to the City Clerk. Operation of a parklet or liquor sales by a licensee without required liability insurance coverage shall be grounds for immediate suspension or revocation of the license. In addition, the licensee shall indemnify and hold harmless the city, the city’s public officials, employees and agents from any loss, costs, damages and expenses arising out of the use, design, operation or maintenance of the parklet. These insurance and indemnification requirements shall be memorialized in a license agreement signed by the licensee prior to the initial issuance of the parklet license and upon any renewal thereof, but failure of the city and the licensee to execute such a license agreement shall not alleviate the licensee of its insurance and indemnification obligations hereunder.*

**LICENSEE HEREBY AGREES** to be bound by the above insurance and indemnification requirements of City of Hastings Ordinance Section 90.17. Licensee shall indemnify and hold the City, the City’s public officials, employees and agents harmless from and against any and all liability, claims, demands, actions, and causes of action, including expenses and reasonable attorneys’ fees, for personal injuries, property damage, or for loss of life or property resulting from, or in any way connected with, Licensee’s use of the Licensed Property and the Right-of-Way area covered by the Parklet License, or any means of ingress or egress from such premises, except liability for personal injuries, property damages, or loss of life or property caused solely by the negligence of the City. Licensee shall implement procedures to ensure no alcohol is sold or provided to minors or allowed outside of the area subject to the Parklet License.

This Agreement is a condition of the Parklet License and confers no rights or benefits upon Licensee, including the continued right to occupy or conduct business operations within the Right-of-Way. The indemnification provisions of this Agreement shall survive expiration, suspension, revocation and any other termination of the Parklet License.

Dated this 5 day of April, 2021.

**CITY**

**CITY OF HASTINGS, A MINNESOTA  
MUNICIPAL CORPORATION**

By: \_\_\_\_\_  
Mary D. Fasbender, Mayor

*(SEAL)*

By: \_\_\_\_\_  
Erica Henderson, City Clerk

Dated this \_\_\_\_ day of \_\_\_\_\_, 2021.

**LICENSEE**

**El Mexican Restaurant of Hastings LLC**

By: \_\_\_\_\_  
David Perez

Its: Owner

**PARKLET LICENSE  
INSURANCE AND INDEMNIFICATION AGREEMENT**

This License Agreement (“Agreement”) is made on April \_\_\_\_\_, 2021, by and between the City of Hastings, a Minnesota Municipal Corporation with a business address of 101 East 4<sup>th</sup> Street, Hastings, MN 55033 (“the City”), and Spiral Brewery, LLC, a Minnesota limited liability company, having a registered office address of 111 2nd Street East, Hastings, MN 55033 (“Licensee”).

The City is owner of a platted and improved street and sidewalk right-of-way for Sibley Street as the same is depicted on the plat of the Town of Hastings on file and of record in the Office of the County Recorder, Dakota County, Minnesota (“the Right-of-Way”).

Licensee operates a food and beverage establishment from property located generally at 111 2<sup>nd</sup> St E, Hastings, MN 55033 and legally on the attached Exhibit A (“the Licensed Property”).

Licensee has been granted a license under City of Hastings Ordinance Section 90.17 to operate a Parklet within an identified portion of the public right-of-way in the street in front of the Licensed Property (“Parklet License”).

As a condition of the Parklet License, Licensee must comply with the following ordinance requirements:

*All parklet licensees must at all times maintain commercial liability insurance covering the licensed premises and the parklet area with minimum policy limits for bodily injury or death of not less than \$1,500,000 per occurrence and \$1,500,000 annual aggregate. Proof of the required liability insurance shall be in the form of a certificate of insurance or some other form acceptable to the City Attorney and City Clerk. All liability insurance policies required herein shall name the city as any additional insured and shall provide that there shall be no cancellation of the policy for any cause, by the insured or by the insurance company, without first giving 10-days’ written notice to the city, addressed to the City Clerk. Operation of a parklet or liquor sales by a licensee without required liability insurance coverage shall be grounds for immediate suspension or revocation of the license. In addition, the licensee shall indemnify and hold harmless the city, the city’s public officials, employees and agents from any loss, costs, damages and expenses arising out of the use, design, operation or maintenance of the parklet. These insurance and indemnification requirements shall be memorialized in a license agreement signed by the licensee prior to the initial issuance of the parklet license and upon any renewal thereof, but failure of the city and the licensee to execute such a license agreement shall not alleviate the licensee of its insurance and indemnification obligations hereunder.*

**LICENSEE HEREBY AGREES** to be bound by the above insurance and indemnification requirements of City of Hastings Ordinance Section 90.17. Licensee shall indemnify and hold the City, the City’s public officials, employees and agents harmless from and against any and all liability, claims, demands, actions, and causes of action, including expenses and reasonable attorneys’ fees, for personal injuries, property damage, or for loss of life or property resulting from, or in any way connected with, Licensee’s use of the Licensed Property and the Right-of-Way area covered by the Parklet License, or any means of ingress or egress from such premises, except liability for personal injuries, property damages, or loss of life or property caused solely by the negligence of the City. Licensee shall implement procedures to ensure no alcohol is sold or provided to minors or allowed outside of the area subject to the Parklet License.

This Agreement is a condition of the Parklet License and confers no rights or benefits upon Licensee, including the continued right to occupy or conduct business operations within the Right-of-Way. The indemnification provisions of this Agreement shall survive expiration, suspension, revocation and any other termination of the Parklet License.

Dated this 5 day of April, 2021.

**CITY**

**CITY OF HASTINGS, A MINNESOTA  
MUNICIPAL CORPORATION**

By: \_\_\_\_\_  
Mary D. Fasbender, Mayor

*(SEAL)*

By: \_\_\_\_\_  
Erica Henderson, City Clerk

Dated this \_\_\_\_ day of \_\_\_\_\_, 2021.

**LICENSEE**

**SPIRAL BREWERY, LLC  
A MINNESOTA LIMITED  
LIABILITY COMPANY**

By: \_\_\_\_\_  
Amy Fox

Its: Owner

**PARKLET LICENSE  
INSURANCE AND INDEMNIFICATION AGREEMENT**

This License Agreement (“Agreement”) is made on April \_\_\_\_\_, 2021, by and between the City of Hastings, a Minnesota Municipal Corporation with a business address of 101 East 4<sup>th</sup> Street, Hastings, MN 55033 (“the City”), and River Investments, Inc., a Minnesota Corporation, doing business as The Busted Nut Bar & Grill, having a registered office address of 118 Second Street East, Hastings, MN 55033 (“Licensee”).

The City is owner of a platted and improved street and sidewalk right-of-way for Second Street as the same is depicted on the plat of the Town of Hastings on file and of record in the Office of the County Recorder, Dakota County, Minnesota (“the Right-of-Way”).

Licensee operates a food and beverage establishment from property located generally at 118 Second Street East, Hastings, MN 55033 and legally described as the West 1/3 of Lot 1, Block 13, Town of Hastings, according to the recorded plat thereof, Dakota County, Minnesota (“the Licensed Property”).

Licensee has been granted a license under City of Hastings Ordinance Section 90.17 to operate a Parklet within an identified portion of the public right-of-way in the street in front of the Licensed Property (“Parklet License”).

As a condition of the Parklet License, Licensee must comply with the following ordinance requirements:

*All parklet licensees must at all times maintain commercial liability insurance covering the licensed premises and the parklet area with minimum policy limits for bodily injury or death of not less than \$1,50,000 per occurrence and \$1,500,000 annual aggregate. Proof of the required liability insurance shall be in the form of a certificate of insurance or some other form acceptable to the City Attorney and City Clerk. All liability insurance policies required herein shall name the city as any additional insured and shall provide that there shall be no cancellation of the policy for any cause, by the insured or by the insurance company, without first giving 10-days’ written notice to the city, addressed to the City Clerk. Operation of a parklet or liquor sales by a licensee without required liability insurance coverage shall be grounds for immediate suspension or revocation of the license. In addition, the licensee shall indemnify and hold harmless the city, the city’s public officials, employees and agents from any loss, costs, damages and expenses arising out of the use, design, operation or maintenance of the parklet. These insurance and indemnification requirements shall be memorialized in a license agreement signed by the licensee prior to the initial issuance of the parklet license and upon any renewal thereof, but failure of the city and the licensee to execute such a license agreement shall not alleviate the licensee of its insurance and indemnification obligations hereunder.*

**LICENSEE HEREBY AGREES** to be bound by the above insurance and indemnification requirements of City of Hastings Ordinance Section 90.17. Licensee shall indemnify and hold the City, the City’s public officials, employees and agents harmless from and against any and all liability, claims, demands, actions, and causes of action, including expenses and reasonable attorneys’ fees, for personal injuries, property damage, or for loss of life or property resulting from, or in any way connected with, Licensee’s use of the Licensed Property and the Right-of-Way area covered by the Parklet License, or any means of ingress or egress from such premises, except liability for personal injuries, property damages, or loss of life or property caused solely by the negligence of the City. Licensee shall implement procedures to ensure no alcohol is sold or provided to minors or allowed outside of the area subject to the Parklet License.

This Agreement is a condition of the Parklet License and confers no rights or benefits upon Licensee, including the continued right to occupy or conduct business operations within the Right-of-Way. The indemnification provisions of this Agreement shall survive expiration, suspension, revocation and any other termination of the Parklet License.

Dated this 5 day of April, 2021.

**CITY**

**CITY OF HASTINGS, A MINNESOTA  
MUNICIPAL CORPORATION**

By: \_\_\_\_\_  
Mary D. Fasbender, Mayor

*(SEAL)*

By: \_\_\_\_\_  
Erica Henderson, City Clerk

Dated this \_\_\_\_ day of \_\_\_\_\_, 2021.

**LICENSEE**

**RIVER INVESTMENTS, INC., A MINNESOTA  
CORPORATION,**

By: \_\_\_\_\_  
Tatia Nelson

Its: Owner

**SIDEWALK CAFÉ LICENSE  
INSURANCE AND INDEMNIFICATION AGREEMENT**

This License Agreement (“Agreement”) is made on April \_\_\_\_, 2021, by and between the City of Hastings, a Minnesota Municipal Corporation with a business address of 101 East 4<sup>th</sup> Street, Hastings, MN 55033 (“the City”), and River Investments, Inc., a Minnesota Corporation, doing business as The Busted Nut Bar & Grill, having a registered office address of 118 Second Street East, Hastings, MN 55033 (“Licensee”).

The City is owner of a platted and improved street and sidewalk right-of-way for Second Street as the same is depicted on the plat of the Town of Hastings on file and of record in the Office of the County Recorder, Dakota County, Minnesota (“the Right-of-Way”).

Licensee operates a food and beverage establishment from property located generally at 118 Second Street East, Hastings, MN 55033 and legally described as the West 1/3 of Lot 1, Block 13, Town of Hastings, according to the recorded plat thereof, Dakota County, Minnesota (“the Licensed Property”).

Licensee has been granted a license under City of Hastings Ordinance Section 90.16 to operate a Sidewalk Café within an identified portion of the public sidewalk or right-of-way immediately adjacent to the Licensed Property (“Sidewalk Café License”).

As a condition of the Sidewalk Café License, Licensee must comply with the following ordinance requirements:

*All sidewalk café licensees must at all times maintain commercial liability insurance covering the licensed premises and the sidewalk café area with minimum policy limits for bodily injury or death of not less than \$1,000,000 per occurrence and \$1,000,000 annual aggregate and for property damage of not less than \$50,000. Proof of the required liability insurance shall be in the form of a certificate of insurance or some other form acceptable to the City Attorney and City Clerk. All liability insurance policies required herein shall name the city as any additional insured and shall provide that there shall be no cancellation of the policy for any cause, by the insured or by the insurance company, without first giving 10-days’ written notice to the city, addressed to the City Clerk. Operation of a sidewalk café or liquor sales by a licensee without required liability insurance coverage shall be grounds for immediate suspension or revocation of the license. In addition, the licensee shall indemnify and hold harmless the city, the city’s public officials, employees and agents from any loss, costs, damages and expenses arising out of the use, design, operation or maintenance of the sidewalk café. These insurance and indemnification requirements shall be memorialized in a license agreement signed by the licensee prior to the initial issuance of the sidewalk café license and upon any renewal thereof, but failure of the city and the licensee to execute such a license agreement shall not alleviate the licensee of its insurance and indemnification obligations hereunder.*

**LICENSEE HEREBY AGREES** to be bound by the above insurance and indemnification requirements of City of Hastings Ordinance Section 90.16. Licensee shall indemnify and hold the City, the City’s public officials, employees and agents harmless from and against any and all liability, claims, demands, actions, and causes of action, including expenses and reasonable attorneys’ fees, for personal injuries, property damage, or for loss of life or property resulting from, or in any way connected with, Licensee’s use of the Licensed Property and the Right-of-Way area covered by the Sidewalk Café License, or any means of ingress or egress from such premises, except liability for personal injuries, property damages, or loss of life or property caused solely by the negligence of the City. Licensee shall implement procedures to ensure no alcohol is sold or provided to minors or allowed outside of the area subject to the Sidewalk Café License.

This Agreement is a condition of the Sidewalk Café License and confers no rights or benefits upon Licensee, including the continued right to occupy or conduct business operations within the Right-of-Way. The indemnification provisions of this Agreement shall survive expiration, suspension, revocation and any other termination of the Sidewalk Café License.



Dated this 5<sup>th</sup> day of April, 2021.

**CITY**

**CITY OF HASTINGS, A MINNESOTA  
MUNICIPAL CORPORATION**

By: \_\_\_\_\_  
Mary D. Fasbender, Mayor

*(SEAL)*

By: \_\_\_\_\_  
Erica Henderson, City Clerk

Dated this \_\_\_\_ day of \_\_\_\_\_, 2021.

**LICENSEE**

**RIVER INVESTMENTS, INC., A MINNESOTA  
CORPORATION,**

By: \_\_\_\_\_  
Tatia Nelson

Its: Owner

**SIDEWALK CAFÉ LICENSE  
INSURANCE AND INDEMNIFICATION AGREEMENT**

This License Agreement (“Agreement”) is made on March\_\_\_\_, 2021, by and between the City of Hastings, a Minnesota Municipal Corporation with a business address of 101 East 4<sup>th</sup> Street, Hastings, MN 55033 (“the City”), and Taproot, LLC, a Minnesota limited liability company, doing business as The Onion Grill, having a registered office address of 1700 Tyler Street, Hastings, MN 55033 (“Licensee”).

The City is owner of a platted and improved street and sidewalk right-of-way for Sibley Street as the same is depicted on the plat of the Town of Hastings on file and of record in the Office of the County Recorder, Dakota County, Minnesota (“the Right-of-Way”).

Licensee operates a food and beverage establishment from property located generally at 100 Sibley Street, Hastings, MN 55033 and legally described as the North 50 feet of Lot 8, Block 4, Town of Hastings, according to the recorded plat thereof, Dakota County, Minnesota (“the Licensed Property”).

Licensee has been granted a license under City of Hastings Ordinance Section 90.16 to operate a Sidewalk Café within an identified portion of the public sidewalk or right-of-way immediately adjacent to the Licensed Property (“Sidewalk Café License”).

As a condition of the Sidewalk Café License, Licensee must comply with the following ordinance requirements:

*All sidewalk café licensees must at all times maintain commercial liability insurance covering the licensed premises and the sidewalk café area with minimum policy limits for bodily injury or death of not less than \$1,000,000 per occurrence and \$1,000,000 annual aggregate and for property damage of not less than \$50,000. Proof of the required liability insurance shall be in the form of a certificate of insurance or some other form acceptable to the City Attorney and City Clerk. All liability insurance policies required herein shall name the city as any additional insured and shall provide that there shall be no cancellation of the policy for any cause, by the insured or by the insurance company, without first giving 10-days’ written notice to the city, addressed to the City Clerk. Operation of a sidewalk café or liquor sales by a licensee without required liability insurance coverage shall be grounds for immediate suspension or revocation of the license. In addition, the licensee shall indemnify and hold harmless the city, the city’s public officials, employees and agents from any loss, costs, damages and expenses arising out of the use, design, operation or maintenance of the sidewalk café. These insurance and indemnification requirements shall be memorialized in a license agreement signed by the licensee prior to the initial issuance of the sidewalk café license and upon any renewal thereof, but failure of the city and the licensee to execute such a license agreement shall not alleviate the licensee of its insurance and indemnification obligations hereunder.*

**LICENSEE HEREBY AGREES** to be bound by the above insurance and indemnification requirements of City of Hastings Ordinance Section 90.16. Licensee shall indemnify and hold the City, the City’s public officials, employees and agents harmless from and against any and all liability, claims, demands, actions, and causes of action, including expenses and reasonable attorneys’ fees, for personal injuries, property damage, or for loss of life or property resulting from, or in any way connected with, Licensee’s use of the Licensed Property and the Right-of-Way area covered by the Sidewalk Café License, or any means of ingress or egress from such premises, except liability for personal injuries, property damages, or loss of life or property caused solely by the negligence of the City. Licensee shall implement procedures to ensure no alcohol is sold or provided to minors or allowed outside of the area subject to the Sidewalk Café License.

This Agreement is a condition of the Sidewalk Café License and confers no rights or benefits upon Licensee, including the continued right to occupy or conduct business operations within the Right-of-Way. The indemnification provisions of this Agreement shall survive expiration, suspension, revocation and any other termination of the Sidewalk Café License.

Dated this 5th day of April, 2021.

**CITY**

**CITY OF HASTINGS, A MINNESOTA  
MUNICIPAL CORPORATION**

By: \_\_\_\_\_  
Mary D. Fasbender, Mayor

*(SEAL)*

By: \_\_\_\_\_  
Erica Henderson, City Clerk

Dated this \_\_\_\_\_ day of \_\_\_\_\_, 2021.

**LICENSEE**

**TAPROOT, LLC, A MINNESOTA  
LIMITED LIABILITY COMPANY,**

By: \_\_\_\_\_  
Wendy Dodge

Its: Owner