



City Council Memorandum

To: Mayor Fasbender & City Council Members
From: Ryan Stempski – Public Works Director/City Engineer
Date: July 5, 2022
Item: Accept Proposal and Authorize Quote from Bigbelly for Purchasing Downtown Garbage Units

Council Action Requested:

The Council is requested to authorize purchase of 14 double units (solid waste bin and recycling bin) from Bigbelly to increase capacity over three times that of the current garbage bins in the downtown area primarily along 2nd Street.

Background Information:

The City of Hastings received rebate funds from Dakota County to be used in 2022 for qualifying projects/expenses. In addition to a shared recycling coordinator position and a trash/recycling study for the City, the Utilities Committee further prioritized purchasing higher capacity trash units in the downtown area. The City received two quotes for trash units downtown (from Bigbelly and Ecube Labs). Bigbelly provided the lower quote and was able to deliver the units within 16 weeks of a signed purchase order. This would allow use of the waste abatement grant from Dakota County required to be spent in 2022. The downtown area has expressed concerns of full trash bins and the need for more frequent removal. In lieu of adding more resources, the Bigbelly units offer an increase in storage for both the recycling and solid waste bins from 16 gallons each to 50 gallons each. These units also come with sensors to provide smart technology back to management to indicate trash levels to better plan visits. The units can be vinyl wrapped to display the City logo and include message paneling to promote events or other City interests that the season brings.

Financial Impact:

The waste abatement grant was approximately \$130,000. The City has already committed \$9,000 of the funds to a shared recycling coordinator position. The Utilities Committee of the Council further directed that study be done on waste/recycling data here in Hastings, which we have budgeted up to \$50,000 to conduct. The Utilities Committee also recommended the use of the grant for this purchase to address trash downtown as a priority. This leaves approximately \$71,000 to use toward purchasing the 14 Bigbelly double units to replace all trash units owned by the City in the downtown area along 2nd Street. The quote of \$64,430 from Bigbelly includes the 14 double units that come with a foot pedal for ADA compliance, a hopper to keep the trash enclosed, a five year warranty, and five year software that includes smart technology that provides trash levels for resource planning. We would like to add vinyl wrapping the City logo for each unit (28) at a total cost of \$4,000 and message paneling for each unit (28) at a cost of \$4,000. This brings the total cost to \$72,430, which is the amount requested by staff to be used of the waste abatement grant for this purchase.

Attachments:

- Bigbelly System Quotation dated June 7, 2022
- Bigbelly Options Brochure



VIII-06

June 7, 2022
Quote Number: Q40446-1
SB / SB

Prices valid for 60 days from above date.

BIGBELLY SYSTEM QUOTATION

Prepared By:
Stu Badertscher Bigbelly Solar 150 A St, Ste 103 Needham, MA 02494 sbadertscher@bigbelly.com

Bill To:
City of Hastings 101 4th Street East Hastings, MN 55033

Ship To:
City of Hastings ,

This order includes the following items:

QTY	ITEM	EXTENDED PRICE
14	SC5.5/SC5.5 Double Station with SC Foot Pedal, SC Hopper, Five Year Warranty, and Five Year CLEAN Software	\$59,850.00

Station pricing includes 5% volume discount based on quantity 28 components.

Shipping & Handling (one time): \$4,580.00

Purchase Option	Total System Cost*:	\$64,430.00 USD
------------------------	----------------------------	------------------------

* Total does not include applicable sales or use taxes.

Sincerely, Stu Badertscher
Bigbelly Solar, LLC

Wire Transfer Info: Middlesex Savings Bank. ▪ Acct Name: Big Belly Solar LLC ▪ Account # 166849558 ▪ Routing # 2113712270 ▪ Int'l Swift # MDSXUS3N

All Purchase Orders must reference the above Quote Number (upper right).

This Quotation is subject to the attached Terms and Conditions of Sale, which are attached hereto and incorporated herein, and expressly acknowledged and accepted by Customer as signified by the duly authorized signature below.

ACCEPTED AND AGREED BY:	
CUSTOMER	
By: _____	Title: _____
Print Name: _____	Date: _____

TERMS AND CONDITIONS OF SALE

Version 9.24.2018

The following Terms and Conditions of Sale ("Agreement") are applicable to any order placed by Customer pursuant to a valid Bigbelly Quotation ("Quotation") that is accepted by Bigbelly ("Order"). Acceptance by Customer of this Agreement, which shall be signified by Customer's duly authorized signature on the face hereof, shall be required for Bigbelly's acceptance of an Order.

1. **SCOPE OF AGREEMENT.** Bigbelly, upon acceptance of an Order placed by Customer, will supply the products to be delivered ("Products") and services to be performed ("Services") as specified in the Quotation to Customer, pursuant to this Agreement and its attachments. Bigbelly's acceptance of an Order is expressly limited to the terms and conditions of this Agreement notwithstanding any contrary provision contained in Customer's purchase orders, acknowledgements or other documents. The details of the Products and Services (e.g. quantity, price, and product specifications) shall be set forth in the relevant Quotation.
2. **ON-SITE SERVICES.** In the event any on-site services (such as installation, warranty repairs) are required as part of the Products and Services, the additional terms set forth in Attachment A attached hereto shall also apply.
3. **PRICE AND PAYMENT.** (a) The prices payable by Customer for the Products and Services by Bigbelly under this Agreement will be specified in the applicable Quotation. Unless otherwise expressly stated in a Quotation, all prices exclude shipping and applicable taxes, all of which are at Customer's expense. (b) Fees shall become payable upon Bigbelly's acceptance of an Order, unless otherwise determined by Bigbelly and agreed to in writing. All late payments made outside of the agreed upon payment terms will be subject to interest at the rate of the lesser of (i) eighteen percent (18%) per annum or (ii) the highest amount allowed under applicable law. Where upfront payment is required, Bigbelly further reserves the right to withhold shipment of the Products and delay performance of the Services until full payment is made. Any failure by Bigbelly to provide an invoice in a timely manner shall not affect Customer's obligation to make payments. (c) Upon reasonable request by Bigbelly, Customer shall provide evidence of its financial capacity and such other information as Bigbelly reasonably requests to determine credit status or credits limits. (d) Customer shall provide notice within five (5) business days of the occurrence of any event which materially affects Customer's ability to perform its obligations under this Agreement.
4. **SHIPPING AND DELIVERY.** Unless otherwise specified and agreed in an Order, Products and Services will be delivered FOB Origin (Bigbelly's manufacturing facility) and will be shipped to Customer at the address provided via carriers selected by Bigbelly at the Customer's expense. The Parties shall mutually agree on any applicable delivery requirements for all Products and Services specified on an applicable Quotation before such Order will be processed. If no delivery requirements are otherwise specified and agreed, Bigbelly shall process any Order upon receipt of the signed Agreement and Customer's fulfillment of any other order processing requirements set forth by Bigbelly in its sole discretion.
5. **INSPECTION AND ACCEPTANCE.** Customer shall promptly inspect the Products and Services upon delivery or completion. In the event Products or Services are received damaged, defective or not to specification, Customer shall provide Bigbelly with prompt notice of the alleged deficiencies in the Products or performance of Services under the Quotation or this Agreement and Bigbelly shall have a reasonable opportunity to cure any such alleged non-conformance.
6. **SOFTWARE LICENSE.** Customer's use of the software provided as a Product and Service ("Software") is subject to the CLEAN Software License Agreement that accompanies delivery of the Software. All applicable terms, provisions and agreements set forth in the CLEAN Software License Agreement are hereby incorporated herein by reference with the same force and effect as though fully set forth herein. To the extent that the terms set forth in this Agreement are inconsistent with the terms of the CLEAN Software License Agreement, the terms set forth herein shall apply.
7. **WARRANTY.** Bigbelly warrants the Products and Services provided pursuant to a Quotation and this Agreement against manufacturer defects or defects in workmanship, under normal use and service, subject to the exclusions, limitations and conditions set forth in the Bigbelly Limited Warranty, set forth in Attachment B and incorporated herein by reference.
8. **BREACH.** In addition to all other rights to which a party is entitled under this Agreement, if either party breaches any term of the Quotation or this Agreement, the non-breaching party shall have the right to: (a) terminate the Quotation immediately upon written notice to the other party; and (b) seek to obtain injunctive relief to prevent such breach or to otherwise enforce the terms of this Agreement. Failure to properly demand compliance or performance of any term of the Quotation or this Agreement shall not constitute a waiver of Bigbelly's rights hereunder and prior to any claim for damages being made for non-conformance or breach, Customer shall provide Bigbelly with prompt notice of any alleged deficiencies in the Products or performance of Services under the Quotation or this Agreement and Bigbelly shall have a reasonable opportunity to cure any such alleged non-conformance or breach.
9. **LIMITATION OF LIABILITY.** IN NO EVENT SHALL BIGBELLY BE LIABLE HEREUNDER FOR INCIDENTAL, SPECIAL, INDIRECT, CONSEQUENTIAL, OR PUNITIVE DAMAGES EVEN IF ADVISED IN ADVANCE OF THE POSSIBILITY FOR SUCH DAMAGES. BIGBELLY'S MAXIMUM AGGREGATE LIABILITY FOR DAMAGES UNDER THIS AGREEMENT AND ANY QUOTATION SHALL BE LIMITED TO THE TOTAL FEES PAID BY CUSTOMER UNDER THE QUOTATION UPON WHICH A CLAIM IS BASED.
10. **INDEMNIFICATION.** Each party, as Indemnitor, shall indemnify, defend and hold harmless the other party, as Indemnitee, its officers, directors, employees, agents, subsidiaries, and other affiliates from and against any and all claims, damages, liabilities, and expenses (including attorney fees) arising from any third-party claim based on Indemnitor's (or its agent's) breach of any representation, warranty, covenant, agreement, or obligation under the Quotation or this Agreement, or Indemnitor's (or its agent's) grossly negligent and/or willful acts or omissions in carrying out its obligations under the Quotation or the Agreement; provided that in no event shall Bigbelly be responsible for any claims arising out of its compliance with instructions, requirements, or specifications provided by or required by Customer (including the use of information, artwork, logos, and/or trademarks provided by Customer). Neither party will be responsible for indemnifying another party hereto where the basis of the indemnity claim arises out of such other party's own negligence or willful misconduct.
11. **CUSTOMER MATERIALS AND DATA.** (a) Customer represents and warrants that any matter it furnishes for the Products or performance of the Services by Bigbelly does not infringe any copyright or trademark or other intellectual property rights of any third party nor does it otherwise violate any laws or infringe the rights of any third party. (b) Customer warrants that it has the right to use, and to have Bigbelly use on behalf of Customer, any data provided to Bigbelly by Customer, including specifically customer names, identifying information, addresses and other contact information and related personal information.
12. **INTELLECTUAL PROPERTY.** Any and all inventions, discoveries, patents, copyrights, trademarks and trade names, commercial symbols, trade secrets, know-how, work product and information or other intellectual property embodying proprietary data existing and owned by Bigbelly as of the date of the Quotation, or made or conceived by employees, consultants, representatives or agents of Bigbelly during the term of this Agreement, shall be and remain at all times the sole and exclusive property of Bigbelly. Customer will obtain no rights thereto other than the limited rights set forth in this Agreement. Without limiting the generality of the foregoing, the parties agree that Bigbelly will own all Software, including all modifications, upgrades and enhancements thereto made during the term of this Agreement.
13. **FORCE MAJEURE.** Any delay or failure of either party to perform its obligations (other than Customer's payment obligation) shall be excused if such failure is caused by an extraordinary event or occurrence beyond the control of the nonperforming party, such as acts of God, fires, floods, windstorms, explosions, natural disasters, wars and sabotage. Each party shall promptly notify the other of the reason for the delay and use its best efforts in curing such cause and shall take all action practicable to minimize the adverse impact of the delay on the other party.
14. **GOVERNING LAW.** Each Quotation and this Agreement shall be governed and construed and enforced in accordance with the laws of the Commonwealth of Massachusetts, without reference to its conflicts of law principles. The Parties further agree (i) that any dispute, controversy or claim arising out of or related to this Agreement shall be brought and settled in the state or federal courts located in Boston, Massachusetts; (ii) to irrevocably submit to the exclusive jurisdiction of any such court; and (iii) to waive any right to a jury trial in any litigation arising out of or related to this Agreement.
15. **COMPLIANCE.** Each party shall comply with all state, federal and local laws and regulations applicable to its performance hereunder.
16. **ASSIGNMENT.** Customer may not assign its rights or obligations under this Agreement without the prior written consent of Bigbelly. Pursuant to a valid assignment, the terms and conditions of this Agreement shall inure to the benefit of and be binding upon the respective successors and assigns of the Parties.
17. **AMENDMENT AND WAIVER.** This Agreement shall not be amended or modified in any way except by a subsequent written agreement signed by authorized persons of both Parties. Any amendment or waiver effected in accordance with this section shall be binding upon the Parties and their respective successors and assigns. The waiver by a Party of any breach by the other Party will not operate or be interpreted as a waiver of any other or subsequent breach, nor shall the failure or delay in exercising any right or seeking any remedy hereunder operate as a waiver thereof.
18. **SEVERABILITY.** If any provision of this Agreement is determined by any court of competent jurisdiction to be invalid or unenforceable, in whole or in part, such provision shall be interpreted to the maximum extent to which it is valid and enforceable, and the remaining provisions of this Agreement shall continue in full force and effect and not be affected thereby.
19. **SURVIVAL.** In the event any provision of the Quotation or this Agreement is held by a tribunal of competent jurisdiction to be contrary to the law, the remaining provisions of the Order or this Agreement will remain in full force and effect. All sections herein relating to payment, ownership, confidentiality, indemnification and duties of defense, representations and warranties, waiver, waiver of jury trial and provisions which by their terms extend beyond the Term shall survive the termination of the Order and this Agreement.

20. NOTICE. Any notice required to be delivered pursuant to this Agreement shall be deemed given when personally delivered to recipient thereof or mailed by registered mail or certified mail, return receipt requested, to the addresses on the Quotation or to such address as either party may designate in the future.
21. ENTIRE AGREEMENT. Each Quotation, together with this Agreement including the Attachments, constitute the entire agreement between the Parties regarding the subject matter hereof and merges and supersedes all prior agreements, oral and written, understandings, commitments and writings. Any Order, purchase order or other ordering or acceptance document issued by Customer is for administrative purposes only and does not form part of this Agreement or amend the terms hereof. In the event of any ambiguity or conflict between any of the terms and conditions contained in this Agreement and the terms and conditions contained in an Order, the terms and conditions of this Agreement shall control. The Quotation or this Agreement may not be amended, supplemented, changed, or modified, except by agreement in writing signed by the parties to be bound thereby.
22. COUNTERPARTS. This Agreement may be executed in counterparts, each of which shall be deemed an original and together shall constitute one instrument.

**ATTACHMENT A
ADDITIONAL TERMS FOR ON-SITE SERVICES**

In the event Bigbelly or its authorized service provides must come on-site to Customer's property in order to perform certain services as part of the Products or Services, the Parties agree that the following terms and conditions shall also apply, as applicable.

For purposes of this Attachment A, the 'Agreement' shall mean the Terms and Conditions of Sale executed between the Parties to which this Attachment A is affixed. The meaning of capitalized and undefined terms appearing herein shall be as set forth in the Agreement unless otherwise indicated. In the event of a conflict between this Attachment A and the Agreement, the terms and conditions of this Attachment A shall prevail solely with respect to the subject matter herein. The terms and conditions of this Attachment A are hereby incorporated into the Agreement by reference.

- 1. INFORMATION AND ACCESS.** Customer agrees that Bigbelly's ability perform the Services under the Agreement in a timely manner is dependent upon access to Customer's installation information and locations. Deadlines imposed by the Agreement shall be extended in the event that Customer fails to provide such information and/or access to Bigbelly in a timely manner.
- 2. SITE PREPARATION.** Customer agrees to provide a poured concrete pad if the intended installation surface does not meet Bigbelly's specifications. If Customer's installation surface does not meet such specifications, any additional cost associated with Bigbelly's efforts to properly prepare the surface will be at Customer's expense. It is the Customer's responsibility to remove, at Customer's expense, existing bins or any other items from the locations where Bigbelly stations will be installed.
- 3. INSTALLATION.** Bigbelly will install the equipment at mutually agreed upon locations, including semi-permanent attachment to the ground. Installation will be in accordance with the delivery and installation schedule agreed to by the Parties prior to commencement of the Services.
- 4. INSURANCE.** Bigbelly shall maintain, during its performance of the Services provided hereunder, liability insurance against claims for injuries to persons or damages to property which may arise from or in connection with the performance of the Services hereunder by Bigbelly. Bigbelly shall furnish copies of such insurance policies upon request.

**ATTACHMENT B
BIGBELLY LIMITED WARRANTY**

Limited Warranty

Big Belly Solar, LLC. ("Bigbelly") provides this limited warranty ("Warranty") to original purchasers (and transferees, as provided below) of new and certified used Bigbelly high capacity and/or standard capacity stations ("Stations"), separately purchased and Bigbelly-authorized component parts ("Parts"), products sold by Bigbelly for use with a Bigbelly Station (Accessories), and any repair performed by Bigbelly on a Station, Part or Accessory pursuant to this Warranty ("Service Repair") purchased in and situated in the United States.

The term, "original purchaser", as used herein, means the first retail purchaser who acquires the new and certified used station(s), Part or Accessory from Bigbelly or an authorized service provider. The term, "purchaser", as used herein, refers to the original purchaser and to any person who acquires the station(s), Parts, Accessories, and Service Repair during the period of Warranty coverage and so notifies Bigbelly in writing of the purchase within ten (10) days of acquiring the station(s).

Subject to the exclusions, limitations and conditions stated herein, Bigbelly warrants a new or certified used Station, battery and Parts against defects in materials and workmanship for a period of one (1) year from date of shipment from Bigbelly to the original purchaser.

Subject to the exclusions, limitations and conditions stated herein, Bigbelly warrants Accessories and all other components of a new or certified used Station against defects in materials and workmanship as follows: (i) Non-consumable Accessories currently sold by Bigbelly – one (1) year from date of shipment from Bigbelly to the original purchaser and (ii) Consumable Accessories currently sold by Bigbelly – thirty (30) days from receipt.

Subject to the exclusions, limitations and conditions stated herein, Bigbelly warrants all Service Repair against defects in materials and workmanship for a period of one (1) year from date of such performance of Services by Bigbelly.

Bigbelly offers no guarantee or warranty of any type on factory or field applied wraps. Bigbelly shall solely determine whether the cause of any failure is a Part or a Service Repair. During the applicable Warranty period, Bigbelly shall, within a reasonable period of time, repair or replace, at its election, the defective component of the Station with new or reconditioned Parts of the same or similar style and with upgraded software, if appropriate, subject to the exclusions, limitations, and conditions stated herein. Any component replaced during the applicable Warranty period will qualify for repair and replacement for the balance of the original applicable Warranty. Bigbelly may elect to simultaneously replace non-defective parts that are part of a sub-assembly that contains the defective component. Any replaced components, Parts or Accessories (defective parts and parts that are part of such a sub-assembly) will become the property of Bigbelly.

This Warranty does not cover damage to a Bigbelly Station, Part or Accessory caused by any of the following: all external causes such as (without limitation) dropping, accident, vandalism, collision, fire, immersion in water; or otherwise using the Station, Part or Accessory contrary to the instructions and warnings contained in the user materials issued by Bigbelly (the "User Materials"); altering or modifying the Station, Part or Accessory; deterioration of paint, trim, and appearance items that results from use and/or exposure to the elements; cleaning with a high-pressure water system, abrasives, or solvents; exposure to environmental conditions beyond the limits stated in the User Materials; failure to properly maintain or improperly servicing the Station, Part or Accessory; damage caused by use of non-Bigbelly parts or accessories; improper charging of the Bigbelly battery; or shipping with methods other than those recommended by Bigbelly. See the User Materials for proper use, maintenance, and charging of a Station, Part or Accessory.

To obtain repair under this Warranty, the purchaser must contact Bigbelly or an authorized service provider within the applicable Warranty period. If you are unable to contact your local authorized service provider, you may contact Bigbelly toll free at (888-820-0300). When contacting the authorized service provider or Bigbelly, be prepared to describe the problem, provide pictures where applicable as well as provide proof of purchase, and serial number of the Bigbelly Station. If the purchaser is unable to resolve the problem with the assistance of the authorized service provider, and if this Warranty applies, the authorized service provider will contact the Bigbelly Service Center to determine the procedure to be followed to repair the Station, Part or Accessory, which may include replacement, at Bigbelly's election.

Bigbelly may provide purchaser with a Return Materials Authorization number ("RMA#"). Purchaser shall then deliver the defective Station, Part or Accessory to Bigbelly or an authorized service provider, (as instructed by Bigbelly), properly packaged (so as to prevent damage during shipment) and with the RMA# written on the outside of the packaging. If the



VIII-06

June 7, 2022

Quote Number: Q40446-1

SB / SB

returned Station, Part or Accessory is defective and this Warranty applies, Bigbelly (or an authorized service provider) shall, within a reasonable period of time, repair the Station, or repair or replace the defective Part or Accessory. Purchaser shall then pick up the repaired Station, or repaired or new or reconditioned Part or Accessory, from Bigbelly or authorized service provider. Purchaser shall pay the cost of shipping to Bigbelly or authorized service provider or other service provider and purchaser shall bear the risk of loss during shipping for any Bigbelly defective Part or Accessory for which purchaser claims this Warranty applies. If this Warranty applies, Bigbelly shall be responsible for paying the cost of shipping to the authorized service provider or purchaser when returning the station, replacement part, or Accessory. Bigbelly obligations and liability for any defects in any station, component part, or Accessory are limited to repair or replacement of defective parts as required by this Limited Warranty. Bigbelly neither assumes (nor authorizes anyone to assume for it) any other obligation or liability in connection with a station, component part, Accessory, Service Repair, or this Limited Warranty.

Bigbelly is not responsible for any loss of use of a Station, Part or Accessory or for any inconvenience or other loss or damage which might be caused from any defect in a Station, Part, Accessory or Service Repair or for any other incidental or consequential damages the purchaser may have as a result of any defect in a Station, Part, Accessory or Service Repair. Without limiting any other exclusion herein, Bigbelly does not warrant that the product covered hereby, including, without limitation, the technology and/or integrated circuit(s) and circuit board(s) included in the product, will not become obsolete or that such items are or will remain compatible with any other product or technology with which the product may be used. This includes, but is not limited to, obsolescence resulting from changes to wireless telecom networks or any other technology.

Optional Extended Warranty Coverage

Extended warranty coverage ("Extended Warranty") on Bigbelly products can be purchased in various increments directly from Bigbelly at the time of the original order. Not all Bigbelly products are eligible for Extended Warranty coverage. Extended Warranty coverage provides the original purchaser an extension of the same level of coverage as the original product Warranty for an additional period, with the exception of coverage for batteries. If you have purchased the Extended Warranty, and it is determined by Bigbelly's Customer Support that your original product requires replacement or repair, the remaining balance of time under the Extended Warranty will also cover the replacement product(s), provided the replacement part is provided by Bigbelly. The Warranty period for the replacement part or repair, including any Extended Warranty period thereof, is calculated from the date of your original product purchase.

THIS WARRANTY AND EXTENDED WARRANTY ARE THE ONLY WARRANTIES APPLICABLE TO BIGBELLY STATIONS, PARTS, ACCESSORIES AND SERVICE REPAIR. BIGBELLY DISCLAIMS ALL OTHER WARRANTIES, EXPRESS OR IMPLIED, INCLUDING IMPLIED WARRANTIES OF MERCHANTABILITY OR FITNESS FOR A PARTICULAR PURPOSE, OTHER THAN THOSE WARRANTIES IMPLIED BY AND INCAPABLE OF EXCLUSION, RESTRICTION, OR MODIFICATION UNDER APPLICABLE LAW. ANY SUCH IMPLIED WARRANTIES WHICH MAY BE REQUIRED BY LAW AND ARE NOT DISCLAIMED HEREBY ARE LIMITED, TO THE EXTENT ALLOWED BY LAW, TO THE APPLICABLE PERIOD OF THIS WARRANTY OR EXTENDED WARRANTY, OR TO THE APPLICABLE TIME PERIOD PROVIDED BY THE APPLICABLE STATE LAW, WHICHEVER PERIOD IS SHORTER. SOME STATES DO NOT ALLOW LIMITATIONS ON HOW LONG IMPLIED WARRANTY LASTS, SO THE ABOVE LIMITATION MAY NOT APPLY TO SOME PURCHASERS. SOME STATES DO NOT ALLOW THE EXCLUSION OR LIMITATION OF INCIDENTAL OR CONSEQUENTIAL DAMAGES, SO THE ABOVE LIMITATION OR EXCLUSION MAY NOT APPLY TO SOME PURCHASERS.

Shipping Terms

Products ship ex works or FOB origin. Please protect your investment against shipping damages and assuming liability by inspecting products upon delivery before signing for them with the shipping company.

Hardware Configuration

Options & Accessories



Bigbelly's Suite of Smart, Connected Waste & Recycling Stations



Bigbelly is the world leader of smart waste & recycling solutions for public spaces. Communities deploy smart, solar-powered, sensor-equipped waste & recycling stations that communicate their real-time status to streamline waste management operations.

Each Bigbelly deployment is comprised of a customized fleet of smart waste & recycling stations. An assessment of the unique challenges and needs of each public space determines the best suited combination of capacity, waste stream, and accessories/options. Stations can be configured as standalone single stations or as multi-stream double or triple stations to accommodate each community's waste stream collections. The full suite of smart stations are field-proven to be durable and street-tough across all environmental conditions.



Two capacities (high & standard) are available to match the varying waste volume needs in every location.



Stations are self-powered (compactors are solar-powered) & do not require connection to an electrical grid.



Each smart station analyzes and monitors its status to make decisions about communications, fullness & alerts.



Sensors located inside each station continuously measure the fullness status, door opens, and collection activity.



On-board GPS provides accurate and up-to-date geolocation for the most precise location-based data.



Smart stations communicate their real-time status and activity to the cloud management system via cellular connection.



High Capacity Stations (HC5)

Smart, Solar-Powered Compacting Model

- Senses & Communicates Fullness Level
- Capacity: 150 Gallons (~570 liters)
- Built-in Compactor (5:1 Compaction Ratio)
- Enclosed Design with Hopper

Standard Capacity Stations (SC5.5)

Smart, Self-Powered Non-Compacting Model

- Senses & Communicates Fullness Level
- Capacity: 50 Gallons (~190 liters)
- Enclosed Design with Optional Hopper

Multi-Stream Configurations

Stations are modular and support any combination of waste streams at each location.
Waste Streams Available: Trash, Recycling - Single Stream, Bottles & Cans, Paper, and Compost/Organics.

Options & Accessories

- Foot Pedal for Hands-Free Use
- Wheeled Interior Lift Bin
- Graphic Wraps, Message Panels and Stickers
- Ashtray and Stub-Out Plates
- Security System with Physical Plates
- External A/C Adapter for Indoor Use

Your Bigbelly system is fully customized to meet the needs and goals of your public space based on enclosure preferences and waste stream (landfill, single vs. multi-stream recycling, compost or organics).

For **High Capacity (HC5) compacting units**, select a waste stream for the enclosed hopper assembly. HCs are always enclosed with a hopper to ensure a physical barrier between the public and the compaction mechanism. In addition to putting safety first, the HC Hopper provides an always enclosed unit to keep waste in and pests out.

For **Standard Capacity (SC5.5) non-compacting units**, first select either an open interface with a faceplate (which includes appropriate deposit holes) or an enclosed hopper assembly, then select a waste stream. With the **SC Hopper** upgrade option, SC units become a completely contained system with a similar aesthetic to HC units' always enclosed design. The SC Hopper keeps waste in and pests out to ensure public space beautification.

Enclosed Hopper

Standard for HC5
Upgrade option for SC5.5



Landfill Waste

Recycling

Compost

Open Faceplate

Standard for SC5.5



Landfill Waste

Single Stream
Recycling

Paper
Recycling

Bottle & Cans
Recycling



Example of HC-SC-HC Triple Station
with HC Hopper for Cans & Bottles Recycling,
SC Faceplate for Paper Recycling
and HC Hopper for Trash



Example of SC-SC Double Station
with SC Hopper for Recycling
and SC Hopper for Trash



For hands-free waste disposal, Bigbelly offers a foot pedal for current generation High Capacity (HC5) and Standard Capacity (SC5.5) stations. Add the amenity and functionality of a foot pedal to enclosed, hopper-equipped stations in your public spaces. Stations with foot pedal upgrade feature the durability and quality of standard compacting and non-compacting stations plus the convenience of hands-free operation, all while keeping waste contained and pests at bay.



- ▶ The step-on foot pedal feature allows for hands-free operation of any HC5 station, and any SC5.5 station that is upgraded to an enclosed hopper interface .
- ▶ The foot pedal is crafted and constructed with strong and durable aluminum and stainless steel, engineered for a smooth and effortless step-on operation.
- ▶ The foot pedal front door has been designed and tested to last over 10 years of tough operation. Bigbelly's rigorous lifecycle and durability testing coupled with controlled field introductions prove functional and environmental endurance. Safety is a priority with our foot pedal designed to initiate a slow "dampened" opening of the hopper as to not injure a small child or a person in a wheelchair
- ▶ Foot pedal operated HC5 and SC5.5 units are self-closing and maintain Bigbelly's proven enclosed design for waste and odor control.



Available factory-installed for any HC5 Components, and SC5.5 Components that are ordered with the SC Hopper.



Leverage your Bigbelly stations' hardware as an eye-catching messaging platform. Drive attention to your desired branding impressions and reach your target audience in a concentrated and visible way.

- ▶ Any configuration of High Capacity and Standard Capacity model stations can be wrapped on all sides.
- ▶ Customizable station wraps are available for any combination of station types.
- ▶ Promote your brand, public service announcements, sponsorships, advertising, and more.
- ▶ The wraps are full-color durable vinyl material and handle any type of weather while resisting fading.
- ▶ Bigbelly's design consultants are available to help you with your design or you can provide your own.
- ▶ Anti-graffiti wrap options also available for commonly vandalized areas.
- ▶ Factory installed prior to deployment. Refer to [Wrap Spec Sheet](#) for full dimensions & additional information.

Station Wrap Dimensions

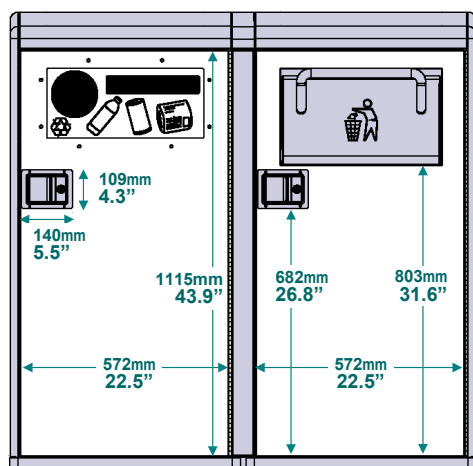

Front / Sidewalk Facing

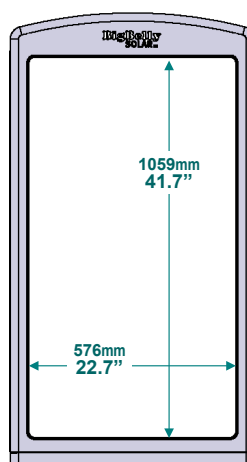

Side of Station

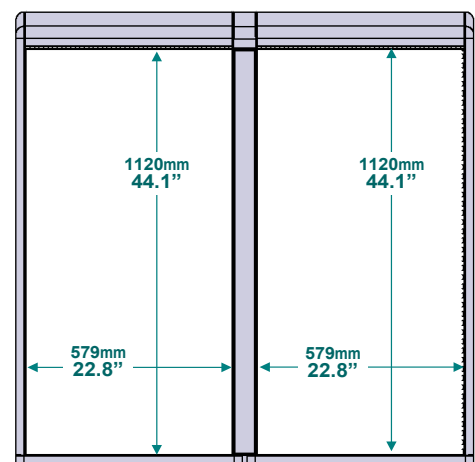

Rear / Street Facing



- ▶ Message panels are perfect if you plan to change out your messaging/advertising regularly for events, seasonal campaigns, or rotating public service announcements.
 - ▶ Message panels are frames to protect and display posters or ads on the sides of stations.
 - ▶ Frame access is secured with tamper-resistant screws which are easy to use to change out graphics
 - ▶ Powder coated aluminum frame with clear polycarbonate face is durable and weather resistant.
 - ▶ Factory installed panel; advertisement interchangeable in the field.

- ▶ Stickers provide you with a smaller, customizable graphic intended to be permanent.
 - ▶ Bigbelly's design consultants are available to help you with your design or you can provide your own.
 - ▶ Oftentimes a logo is a powerful and lasting design that pairs well with rotating message panels.
 - ▶ Factory installed prior to deployment.

- ▶ Please refer to [Messaging Options Spec Sheet](#) for full options, dimensions and additional information.



Stickers / Decals
Front / Sidewalk Facing



Message Panel
Side of Station

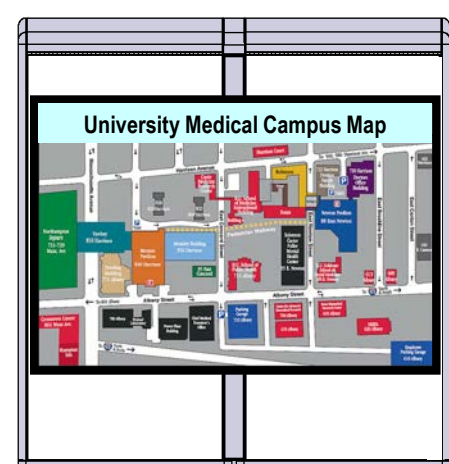

Rear Message Panel
Rear / Street Facing

Standardized Labels in Partnership with Recycle Across America

Bigbelly's world leading smart waste and recycling solution notifies collection crews when bins are ready for pick-up, then measure and report on recycling diversion. This smart, sustainable solution provides uniform recycling program and offers distinctive, standardized recycling education at the point of disposal... a win-win!



Bigbelly has partnered with **Recycle Across America** (www.recycleacrossamerica.org), the 501(c)(3) nonprofit organization on a mission to implement a standardized label solution to make it easy for society to recycling right. **Let's recycle right!** Our partnership delivers RAA's standardized labels custom-sized for Bigbelly's smart waste & recycling stations - compatible with both High Capacity (HC) and Standard Capacity (SC) models.

Standardized labels further enhance the impact of Bigbelly's uniform system that measures and reports on recycling diversion while reducing communities' overall environmental footprint. Help make your recycling programs thrive with Recycle Across America's standardized labels on your new Bigbelly stations.

Recycle Across America offers labels for every sorting need that come in two sizes: 11x17-inch (for placement on the station front doors) as well as Message Panel Inserts with their celebrity Let's recycle right! PSAs (18x30-inch).

Explore and order standardized labels custom-sized for Bigbelly units: www.recycleacrossamerica.org/bigbelly-bins 



Recycle Across America has created the world's first and only society-wide standardized labels for bins to make it easy for people to recycle right wherever they are, and therefore help recycling and closed-loop manufacturing begin to thrive. The standardized labels are proven to increase recycling levels 50-100% and dramatically decrease the amount of contamination (aka garbage) thrown in recycling bins; therefore, improving the financial viability of recycling.

Bigbelly offers ashtrays and stub-out plates to encourage proper disposal of cigarettes in your outdoor public spaces.

Option 1: Ashtray with Stub-Out Plates

- ▶ The ashtray is accessible by the user on the front door beneath the hopper.
- ▶ The ashtray bin is easy to empty when collecting the station's waste.
- ▶ The stub-out plates are located on each side of the station to encourage smokers to stub out their cigarette on the intended plate rather than the HC5's plastic solar panel bubble or exterior plastic.
- ▶ Ashtray and two stub-out plates per station are factory installed.



Stub-Out Plate

Option 2: Stub-Out Plates (2 per station)

Available for HC5 Components.

Ashtray with Built-In Stub-Out Plate



Front Door



Inside Front Door



Removable Ashtray



Bigbelly recommends an High Energy Solar Panel for an European, Canadian, or urban canyon locations (tall skyscrapers blocking light from the street level) to ensure plentiful energy collection.

Solar-powered waste compactors must function successfully over the life of the station using only the solar energy available at waste bin locations. This means success without direct sunlight, in high latitudes, short days of winter, high traffic, and shaded locations. While the standard HC5 solar panels pack a punch, some areas of the world simply do not get as much sunlight as others. Consider the short daylight hours of Northern Scandinavia and Canada compared to the long sunny days of Australia and the Middle East, or the “urban canyons” of high-traffic New York City compared to a suburban college campus.

High Energy Solar Panels are factory-installed prior to deployment and will be recommended by your account manager if needed. All HC5 solar-powered waste compactors come equipped with Bigbelly’s patented energy management technology. High Energy options are not required or available for the battery-powered SC5.5 model.

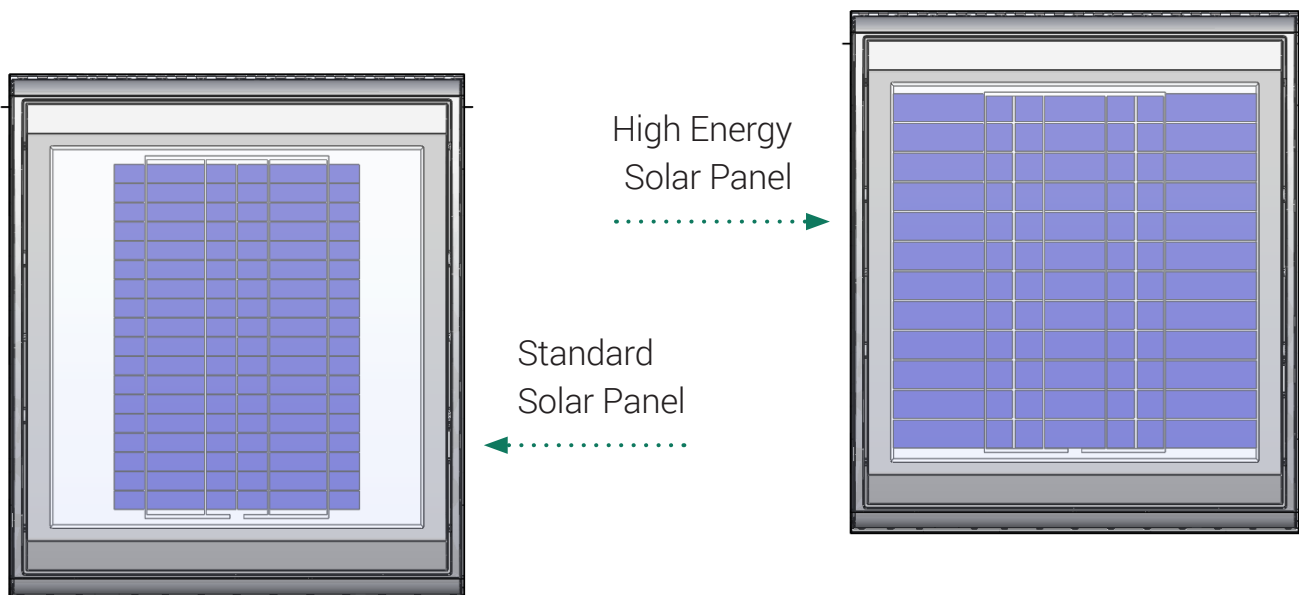

The Bigbelly system benefits can be taken indoors by leveraging an external power supply in order to provide power to stations for compaction and communication with CLEAN.

The Bigbelly system can be used indoors in public spaces such as corporate offices, indoor cafeterias, malls and retail stores, college residence halls, and healthcare public spaces. Bring reduced collection frequency, remote monitoring, and total waste containment inside.

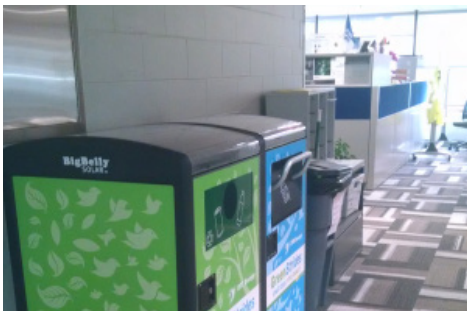
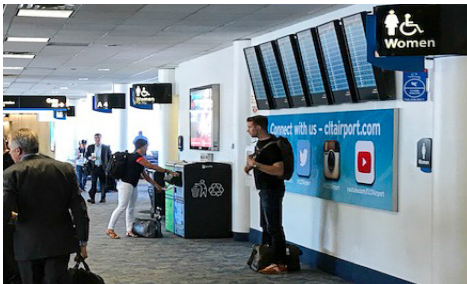

- ▶ The fundamental design of the Bigbelly HC station only utilizes low voltage (12V) inside the station. All energy required for compactions, communications, and standby is pulled from a 12V battery. The use of low voltage and a grounded chassis eliminates any possible for electric shock.
- ▶ Indoor usage of HC5 model station runs on the same safe, low voltage system with battery storage.
- ▶ The addition of an A/C adapter turns HC5 stations into a hybrid system with two power sources in the case that your station is every moved for outside use. The Bigbelly HC station uses a fully certified DC power adaptor that is located outside of the station and uses less than .25A at 120V.
- ▶ This power adaptor provides the DC voltage to the station that is used to charge the internal battery. The A/C adapter plugs into the back of the station using standard 110/220 Volt outlets with plug connectors for USA, UK, and European markets.
- ▶ External Power Supply is not required or available for the battery-powered SC5.5 model which properly functions in either indoor or outdoor environments. The SC5.5's Alkaline battery has a lifespan of ~8 years.

Bigbelly offers removable Hopper Liners that are easy to clean off-site and will keep your HC and SC hopper interiors neat and tidy.

While Bigbelly's stations are built street tough and durable, receptacles in areas with high amounts of organic waste - such as ice cream shops, food courts, picnic areas, and transit stops - can leave unsightly hoppers. Eliminate the complaints and the mess by adding hopper liners to your stations.



- ▶ Help keep surfaces presentable: hopper liners are recommended to keep the main chute to the interior bin as clean as possible when patrons deposit waste.
- ▶ Deters bees and bugs: Sugary foods and drink residue attract bees and other insects. Keep the hopper clean to prevent your station from becoming a bug magnet.
- ▶ All HC5 stations and SC5.5 stations with SC Hopper upgrade ship with one hopper liner; additional are available to purchase as spare parts. Two hopper liners per station are recommended - one for station use and one for replacement when the alternate is being cleaned. The durable plastic design is tested to withstand pressure washing. Multi-time use is encouraged.
- ▶ When hopper liners are ready to be permanently replaced after multiple uses, they can be recycled.





Refuse collection trucks with a semi-automated lift arm loader are increasingly popular around the world for waste collection. Semi-automated collection vehicles feature a lift arm compatible with wheeled bins. This collection technique eases collection work while reducing the risk of injury due to lifting or maneuvering heavy waste bins. For customers using bar- and comb-style semi-automated lift arm collection vehicles, Bigbelly offers a durable and ergonomic wheeled lift bin. This lift bin option is available for both HC and SC units instead of the standard inner bin.

- ▶ Semi-automatic collection trucks with wheeled lift bins are increasingly used to reduce the heavy lifting associated with refuse collection. This is an advantage for many cities and towns which strive towards the most safe and productive waste collection.
- ▶ The combination of the lift bin collection technique and optimized use of the Bigbelly smart waste and recycling system provides the most efficient public space waste operations.
- ▶ The HC lift bin is the only lift arm compatible bin proven to work effectively with compaction technology. The wheeled lift bin for HC features a patented telescoping design which allows it to be identical in size to a standard HC5 interior bin when collapsed. It expands vertically to support compatible lift arm collection systems.
- ▶ The SC lift bin features a custom wheeled design, allowing for ergonomic collection with purpose-built fit for the station to ensure proper waste flow into inner bin while matching height requirements.
- ▶ Both HC and SC Lift Bins are available in either comb-style and bar-style lift arm versions. New orders and field upgrades are available for use with current generation stations designated for any waste stream.
- ▶ Lift-Arm Mechanism Compatibility:
 - ▶ Bar-Style: US 2-Bar; Type B (ANSI Z245.60-2008)
 - ▶ Comb-Style: DIN EN 1501-5

SC Lift Bin

Purpose-Built Design for Ergonomic Collection & Proper Waste Flow

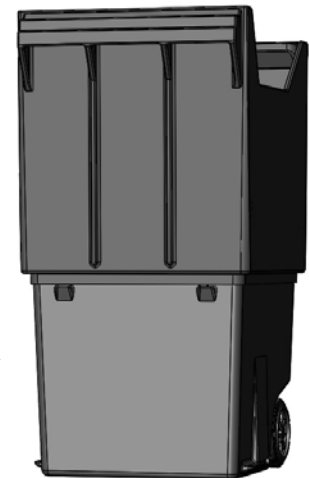
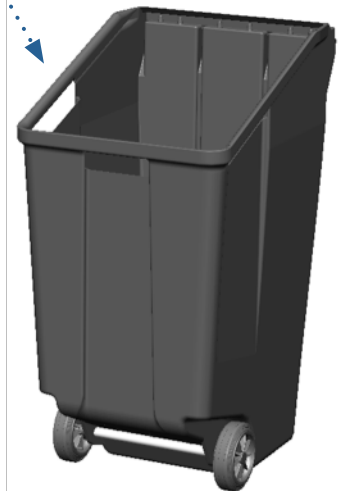

*Expanded
Lift Bin*

HC Lift Bin

*Patented Collapsing Bin Design for
Maximum Compaction Capability*

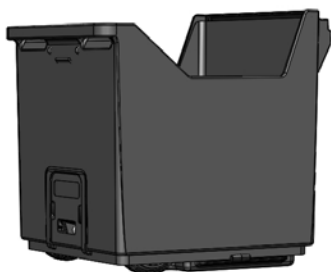

*Collapsed
Lift Bin*

*Pictured: Comb-Style Lift Arm
Also available: Bar-Style Lift Arm*

For high profile public space events, Bigbelly offers a complete security package for your system. The Bigbelly Security System consists of two components - the Security Management Module within CLEAN that enables operations to set up and manage security events and physical Security Plates that prevent access to the stations.

The Bigbelly Security System restricts physical access to stations and alerts authorities via email or text if a station is breached. The system saves operational time and costs by eliminating the need to remove Bigbelly stations during special events.



► Security Management Module

The Security Management Module resides within Bigbelly’s CLEAN Management Console and provides the following functionality via an easy-to-use set up wizard:

- Event Creation - *Create and easily add or delete stations from a security event via interactive map*
- Event Scheduling - *Stations are automatically placed into and removed from Secure Mode based on the specified event start and end time*
- Security Notifications - *Alerts and Notifications can be sent to any staff or law enforcement personnel*
- Security Dashboard - *Easily monitor and manage security events directly within the CLEAN software platform*

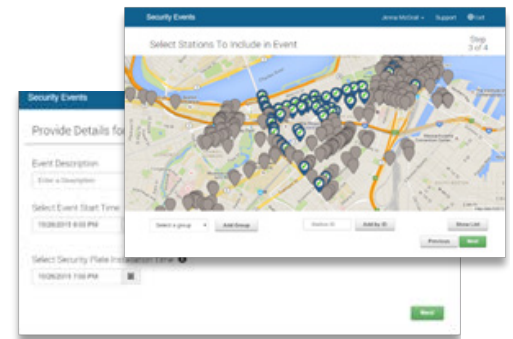

► Security Plates

Security Plates are installed during special events to prevent access to your fleet of Bigbelly smart stations. Custom graphics can be added to communicate that the stations are out of service. Security plates are available for purchase by all new customers and existing customers.



Waste & Recycling Liner Bags

Bigbelly recommends the usage of our customized WasteZero waste and recycling bags to optimum performance.

- ▶ High Capacity station bags are sold by the case, 50 bags/case.
- ▶ Standard Capacity station bags are sold by the case, 100 bags/case.
- ▶ Liner bags are available to purchase with all initial Bigbelly station orders. Refills may be purchased from preferred partner, WasteZero, at shop.wastezero.com/Bigbelly/ or +1-800-866-3954.
- ▶ Refer to [Liner Bag Spec Sheet](#) for compatible heavy duty liner bag specifications and additional information.



Solar Bubble Plastic Cleaning Kit

A three step cleaning and polishing kit is available for the plastic solar bubble of any Bigbelly machine.

- ▶ If your station's solar bubble is appearing cloudy or hazy, we recommend this cleaning & polishing kit.
- ▶ Three step cleaning process that clears any dirt or fog from the solar bubble and the solution also fills in any minor cracks or scratches on the plastic.



Station Odor Mask Kit

An odor mask kit and refill pads are available for purchase and field installation for your Bigbelly smart waste fleet. While Bigbelly stations' enclosed design keeps the litter and smells in and the pests out, the odor mask kit is an accessory to keep the stations as fresh as possible.

- ▶ The Odor Mask Kit comes with Cucumber Melon scented odor shield pads coupled with a holder.
- ▶ Installation into stations is quick & easy; the recommended placement is near hopper or flap opening for best results.
- ▶ Refills of the odor pads help to shield the waste odor upon hopper or front-door opening.



Bigbelly recommends usage of the a Standard Capacity Inner Bin Sleeve for any SC5 or SC5.5 station to proactively protect these public waste stations from unlawful pilfering and for station sensor & fullness reporting accuracy.

Does your public space experience extreme cases of pilfering through landfill or recycling waste streams? Bigbelly has developed our patented SC Sleeve to hold the interior bin's liner bag in place and recyclables or other waste out of reach of the pilferers.

Optional anti-pilfering brackets are available and recommended in urban areas to further constrain the interior bin bag and protect from unauthorized access.

In addition to keeping the bag in place, which deters pilfers from accessing waste in the bin, the patented SC Sleeve also ensures proper sensor readings which connect and communicate fullness via CLEAN software. "Know when to go" and collect your stations when they are ready, rather than making them an easy pilfering target.

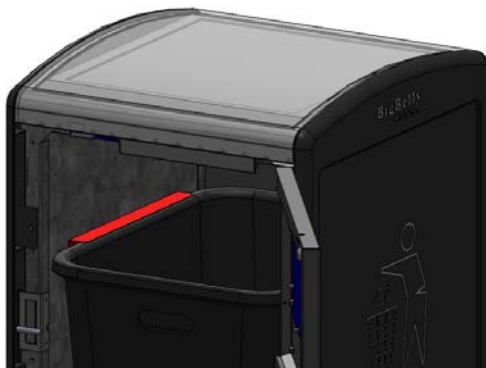

- ▶ The Standard Capacity Inner Bin Sleeve ships standard with all SC5 and SC5.5 components. It improves the performance of the system by proactively protecting against unlawful pilfering and ensuring accurate sensor readings.
- ▶ This optional Standard Capacity Inner Bin Sleeve proves particularly useful in situations where you continually experience incorrect bag positioning and subsequent errors via CLEAN Management Console. The SC Sleeve's impact on sensor reading and data accuracy is a critical feature of the Bigbelly SC model that differentiates this smart bin from competitive sensor-based waste bin products.
- ▶ Bigbelly recommends the use of our preferred waste and recycling bags from WasteZero (www.wastezero.com/bigbelly - available in the USA only) to avoid incorrect bag positioning.
- ▶ Additional anti-pilfering brackets (shown to the left) are available to further constrain waste access from station opening. These brackets are easy to install on any station already deployed in the field.

Each generation of Bigbelly stations has featured a lock redesign to increase security and upgrade technology. If you have a Bigbelly fleet which contains a mix of HC3/CR, HC4/SC4, and HC5/SC5/SC5.5 models, a lock option kit is available to streamline collection and maintenance of your fleet with a single key.

Please contact Bigbelly customer service (support@bigbelly.com or +1-781-444-6002 extension 3) to determine the best solution for your lock and key situation. This can also be used to terminate unlawful possession of station keys.

HC5/SC5/SC5.5 Models

Top Key



Front Key



Latch



Back View of Door Lock



Single-Sided
Key Option



HC4/SC4 Models

Top Key



Front Key



Latch



Back View of Door Lock



Single-Sided
Key Option



HC3 Models

Top & Front Key



Latch



Back View of Door Lock

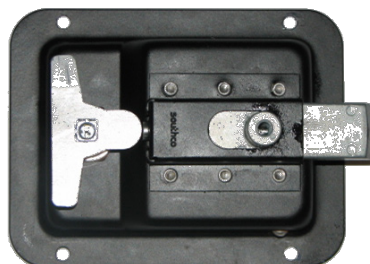

Double-Sided
Key Option

